

53-1003077-01
08 January 2014



Brocade FCX Series

Hardware Installation Guide

Supporting FastIron Software Release 08.0.10

BROCADE

© 2014, Brocade Communications Systems, Inc. All Rights Reserved.

Brocade, the B-wing symbol, Brocade Assurance, ADX, AnyIO, DCX, Fabric OS, FastIron, HyperEdge, ICX, MLX, MyBrocade, NetIron, OpenScript, VCS, VDX, and Vyatta are registered trademarks, and The Effortless Network and the On-Demand Data Center are trademarks of Brocade Communications Systems, Inc., in the United States and in other countries. Other brands and product names mentioned may be trademarks of others.

Notice: This document is for informational purposes only and does not set forth any warranty, expressed or implied, concerning any equipment, equipment feature, or service offered or to be offered by Brocade. Brocade reserves the right to make changes to this document at any time, without notice, and assumes no responsibility for its use. This informational document describes features that may not be currently available. Contact a Brocade sales office for information on feature and product availability. Export of technical data contained in this document may require an export license from the United States government.

The authors and Brocade Communications Systems, Inc. assume no liability or responsibility to any person or entity with respect to the accuracy of this document or any loss, cost, liability, or damages arising from the information contained herein or the computer programs that accompany it.

The product described by this document may contain open source software covered by the GNU General Public License or other open source license agreements. To find out which open source software is included in Brocade products, view the licensing terms applicable to the open source software, and obtain a copy of the programming source code, please visit <http://www.brocade.com/support/oscd>.

Contents

- Preface..... 5**
 - Document conventions..... 5
 - Text formatting conventions..... 5
 - Command syntax conventions..... 5
 - Notes, cautions, and warnings..... 6
 - Brocade resources..... 7
 - Getting technical help..... 7
 - Document feedback..... 8

- About This Document..... 9**
 - Introduction..... 9
 - Supported Software..... 9
 - What's new in this document 9

- Product Overview..... 11**
 - Hardware features..... 11
 - Control features..... 15
 - Power supplies..... 31

- Installing the FCX Switch..... 33**
 - Unpacking the device..... 33
 - Package contents..... 33
 - General requirements..... 33
 - Installation tasks..... 34
 - Installation precautions..... 35
 - General precautions..... 35
 - Lifting precautions..... 35
 - Power precautions..... 35
 - Preparing the installation site..... 36
 - Cabling infrastructure..... 36
 - Installation location..... 36
 - Installing the device..... 37
 - Desktop installation..... 37
 - Rack mount installation..... 38
 - Connecting devices in a traditional stack..... 41
 - Stacking ports..... 41
 - Stacking configuration requirements..... 44
 - Stacking cables..... 44
 - Stack size..... 44
 - Stacking topologies..... 44
 - Extended distance stacking..... 48
 - Powering on the system..... 48
 - Attaching a PC or terminal..... 49
 - Wiring map for serial cable..... 50
 - Installing and replacing a power supply unit..... 50
 - Installing or replacing fan trays..... 52
 - Installing an optional module 53

Optional 2-port 10 Gbps SFP+ uplink module.....	55
Checking Network Devices and Testing Connectivity.....	59
Assigning permanent passwords.....	59
Setting passwords.....	60
Recovering from a lost password.....	60
Configuring IP addresses.....	61
Devices running Layer 2 software.....	61
Devices running Layer 3 software.....	62
Connecting network devices.....	65
Connectors.....	65
Cable specifications.....	65
Connecting to Ethernet or fast Ethernet hubs.....	65
Connecting to workstations, servers, or routers.....	66
Connecting a network device to a fiber port.....	67
Testing connectivity.....	71
Pinging an IP address.....	71
Observing LEDs.....	71
Tracing a route.....	73
Troubleshooting network connections.....	74
Using Virtual Cable Testing to diagnose a cable.....	74
Digital optical monitoring.....	75
Managing the FCX Hardware.....	77
Managing temperature settings.....	77
Using the temperature sensor.....	77
Removing MAC address entries.....	80
Displaying FCX CPU usage.....	81
Hardware maintenance schedule.....	81
Replacing a copper or fiber optic module.....	81
Removing a copper or fiber optic module.....	81
Cabling a fiber optic module.....	83
Cleaning the fiber optic connectors.....	83
Hardware Specifications.....	85
Hardware specifications.....	85
Physical dimensions and weight.....	85
Environmental considerations.....	85
Cooling system and fans.....	86
Pinouts and signalling.....	89
Cable specifications.....	91
Power cords.....	92
AC power supply specifications.....	93
Troubleshooting.....	95
Diagnosing switch indicators.....	95
Power and cooling problems.....	95
Installation.....	95
In-band access.....	95
Regulatory Statements.....	97
USA (FCC CFR 47 Part 15 Warning).....	97

Industry Canada statement.....	97
Europe and Australia (CISPR 22 Class A Warning).....	98
Germany (Noise Warning).....	98
Japan (VCCI).....	98
Japan power cord.....	98
Korea.....	99
China.....	100
BSMI statement (Taiwan).....	100
Regulatory compliance.....	101
Cautions and Danger Notices.....	103
Cautions.....	103
Danger notices.....	107

Preface

- Document conventions.....5
- Brocade resources.....7
- Getting technical help.....7
- Document feedback.....8

Document conventions

The document conventions describe text formatting conventions, command syntax conventions, and important notice formats used in Brocade technical documentation.

Text formatting conventions

Text formatting conventions such as boldface, italic, or Courier font may be used in the flow of the text to highlight specific words or phrases.

Format	Description
bold text	Identifies command names Identifies keywords and operands Identifies the names of user-manipulated GUI elements Identifies text to enter at the GUI
<i>italic text</i>	Identifies emphasis Identifies variables and modifiers Identifies paths and Internet addresses Identifies document titles
<code>Courier font</code>	Identifies CLI output Identifies command syntax examples

Command syntax conventions

Bold and italic text identify command syntax components. Delimiters and operators define groupings of parameters and their logical relationships.

Convention	Description
bold text	Identifies command names, keywords, and command options.
<i>italic text</i>	Identifies a variable.

Convention	Description
value	In Fibre Channel products, a fixed value provided as input to a command option is printed in plain text, for example, --show WWN .
[]	Syntax components displayed within square brackets are optional. Default responses to system prompts are enclosed in square brackets.
{ x y z }	A choice of required parameters is enclosed in curly brackets separated by vertical bars. You must select one of the options. In Fibre Channel products, square brackets may be used instead for this purpose.
x y	A vertical bar separates mutually exclusive elements.
< >	Nonprinting characters, for example, passwords, are enclosed in angle brackets.
...	Repeat the previous element, for example, <i>member[member...]</i> .
\	Indicates a "soft" line break in command examples. If a backslash separates two lines of a command input, enter the entire command at the prompt without the backslash.

Notes, cautions, and warnings

Notes, cautions, and warning statements may be used in this document. They are listed in the order of increasing severity of potential hazards.

NOTE

A note provides a tip, guidance, or advice, emphasizes important information, or provides a reference to related information.

ATTENTION

An Attention statement indicates potential damage to hardware or data.



CAUTION

A Caution statement alerts you to situations that can be potentially hazardous to you or cause damage to hardware, firmware, software, or data.



DANGER

A Danger statement indicates conditions or situations that can be potentially lethal or extremely hazardous to you. Safety labels are also attached directly to products to warn of these conditions or situations.

Brocade resources

Visit the Brocade website to locate related documentation for your product and additional Brocade resources.

You can download additional publications supporting your product at www.brocade.com.

- Adapter documentation is available on the [Downloads and Documentation for Brocade Adapters](#) page. Select your platform and scroll down to the Documentation section.
- For all other products, select the Brocade Products tab to locate your product, then click the Brocade product name or image to open the individual product page. The user manuals are available in the resources module at the bottom of the page under the Documentation category.

To get up-to-the-minute information on Brocade products and resources, go to [MyBrocade](#). You can register at no cost to obtain a user ID and password.

Release notes are available on [MyBrocade](#) under Product Downloads.

White papers, online demonstrations, and data sheets are available through the [Brocade website](#).

Getting technical help

You can contact Brocade Support 24x7 online, by telephone, or by e-mail.

For product support information and the latest information on contacting the Technical Assistance Center, go to <http://www.brocade.com/services-support/index.html>.

Use one of the following methods to contact the Brocade Technical Assistance Center.

Online	Telephone	E-mail
Preferred method of contact for non-urgent issues:	Required for Sev 1-Critical and Sev 2-High issues:	support@brocade.com
<ul style="list-style-type: none"> • My Cases through MyBrocade • Software downloads and licensing tools • Knowledge Base 	<ul style="list-style-type: none"> • Continental US: 1-800-752-8061 • Europe, Middle East, Africa, and Asia Pacific: +800-AT FIBREE (+800 28 34 27 33) • For areas unable to access toll free number: +1-408-333-6061 • Toll-free numbers are available in many countries. 	Please include: <ul style="list-style-type: none"> • Problem summary • Serial number • Installation details • Environment description

Document feedback

To send feedback and report errors in the documentation you can use the feedback form posted with the document or you can e-mail the documentation team.

Quality is our first concern at Brocade and we have made every effort to ensure the accuracy and completeness of this document. However, if you find an error or an omission, or you think that a topic needs further development, we want to hear from you. You can provide feedback in two ways:

- Through the online feedback form in the HTML documents posted on www.brocade.com.
- By sending your feedback to documentation@brocade.com.

Provide the publication title, part number, and as much detail as possible, including the topic heading and page number if applicable, as well as your suggestions for improvement.

About This Document

- [Introduction.....](#) 9
- [What's new in this document](#) 9

Introduction

This guide includes procedures for installing and maintaining the hardware. The hardware procedures show how to install or assemble the various hardware components with the necessary precautions, warnings, and regulatory statements. This guide also describes the required device specifications for running the hardware.

Supported Software

For information about the features supported on a hardware platform, refer to the appropriate configuration guide.

What's new in this document

This document is enhanced to support the current FastIron release 08.0.10.

What's new in this document

Product Overview

- [Hardware features.....](#) 11

Hardware features

The following hardware platforms are supported by this release of this guide:

- The Brocade FCX 624S stackable switch has twenty 10/100/1000 Mbps ports plus four Combo ports, which include four 10/100/1000 Mbps RJ45 ports and four 100/1000 Mbps SFP ports. The switch has two management interfaces, a DB9 serial port (Console) on the front panel and an RJ45 port (Out-of-band Management Interface) on the rear panel. Two rear-panel power supply receptacles allow for up to two power supply units. Two dedicated 16 GbE CX4 ports on the rear panel allow stacking for up to eight units. The front panel also has a module slot for an optional two-port 10 Gbps XFP module.
- The Brocade FCX 648S stackable switch has forty four 10/100/1000 Mbps RJ45 ports plus four Combo ports, which include four 10/100/1000 Mbps RJ45 ports and four 100/1000 Mbps SFP ports. The switch has two management interfaces, a DB9 serial port (Console) on the front panel and an RJ45 port (Out-of-band Management Interface) on the rear panel. Two rear-panel power supply receptacles allow for up to two power supply units. Two dedicated 16 Gbps Ethernet CX4 ports on the rear panel allow stacking for up to eight units. The front panel also has a module slot for an optional two-port 10 Gbps Ethernet XFP module.
- The Brocade FCX 624S-F stackable switch has two management interfaces, a DB9 serial port (Console) on the front panel and an RJ45 port (Out-of-band Management Interface) on the rear panel. Two rear-panel power supply receptacles allow for up to two power supply units. Two dedicated 16 Gbps Ethernet CX4 ports on the rear panel allow stacking for up to eight units. The front panel also has a module slot for an optional two-port 10 Gbps Ethernet XFP module.
- The Brocade FCX 624S-HPOE stackable switch has twenty 100/1000 Mbps ports plus four Combo ports, which include four 10/100/1000 Mbps RJ45 ports and four 100/1000 Mbps SFP ports. The switch has two management interfaces, a DB9 serial port (Console) on the front panel and an RJ45 port (Out-of-band Management Interface) on the rear panel. Two rear-panel power supply receptacles allow for up to two power supply units. Two dedicated 16 Gbps Ethernet CX4 ports on the rear panel allow stacking for up to eight units. The front panel also has a module slot for an optional two-port 10 Gbps Ethernet XFP module.
- The Brocade FCX 648S-HPOE has is a stackable switch with forty four 10/100/1000 Mbps ports plus four Combo ports, which include four 10/100/1000 Mbps RJ45 ports and four 100/1000 Mbps SFP ports. The switch has two management interfaces, a DB9 serial port (Console) on the front panel and an RJ45 port (Out-of-band Management Interface) on the rear panel. Two rear-panel power supply receptacles allow for up to two power supply units. Two dedicated 16 Gbps Ethernet CX4 ports on the rear panel allow stacking for up to eight units. The front panel also has a module slot for an optional two-port 10 Gbps Ethernet XFP module.
- The Brocade FCX 624-E switch has twenty four 10/100/1000 Mbps ports. The device has two management interfaces on the front panel, a DB9 serial port (Console) and an RJ45 port (Out-of-band Management Interface). The front panel has a slot for an optional four-port 1GbE SFP module (works as Combo port) or four-port 10 Gbps SFP+ module. On the rear panel a removable fan tray provides a cooling airflow from the front to the rear of the device. Two rear-panel power supply receptacles accommodate up to two power supply units that also support a front-to-rear cooling airflow.

- The Brocade FCX 624-I switch has twenty four 10/100/1000 Mbps ports. The device has two management interfaces on the front panel, a serial port (Console) and an RJ45 port (Out-of-band Management Interface). The front panel has a slot for an optional four-port 1GbE SFP module (works as Combo port) or four-port 10 Gbps SFP+ module. On the rear panel a removable fan tray provides a cooling airflow from the rear to the front of the device. Two rear-panel power supply receptacles accommodate up to two power supply units that also support a rear-to-front cooling airflow.
- The Brocade FCX 648-E switch has forty four 10/100/1000 Mbps ports. The device has two management interfaces on the front panel, a serial port (Console) and an RJ45 port (Out-of-band Management Interface). The front panel has a slot for an optional four-port 1GbE SFP module (works as Combo port) or four-port 10 Gbps SFP+ module. On the rear panel a removable fan tray provides a cooling airflow from the front to the rear of the device. Two rear-panel power supply receptacles accommodate up to two power supply units that also support a front-to-rear cooling airflow..
- The Brocade FCX 648-I switch has forty four 10/100/1000 Mbps ports. The device has two management interfaces on the front panel, a serial port (Console) and an RJ45 port (Out-of-band Management Interface). The front panel has a slot for an optional four-port 1GbE SFP module, (works as Combo port) or four-port 10 Gbps SFP+ module. On the rear panel a removable fan tray provides a cooling airflow from the rear to the front of the device. Two rear-panel power supply receptacles accommodate up to two power supply units that also support a rear-to-front cooling airflow.

NOTE

All FCX models support Layer 2 and Enterprise Layer 3 protocols (RIP, OSPF, PIM). FCX models can be ordered from the factory as -ADV (Advanced Layer 3) models, which adds support for the Layer 3 BGP routing protocol and GRE.

The following sections describe the physical characteristics of the FastIron CX models. For more details about physical dimensions, power supply specifications, and pinouts, refer to the "Hardware Specifications" section.

The following figures show the front panels of the FastIron CX models. For more information about Combo ports, see [Network interfaces for Brocade FCX 624-E, FCX 624-I, FCX 648-E, and FCX 648-I](#)

on page 15. For more information about control features in general, see [Control features](#) on page 15.

FIGURE 1 Brocade FCX 624S front panel



FIGURE 2 Brocade FCX 648S front panel



FIGURE 3 Brocade FCX 624S-F front panel

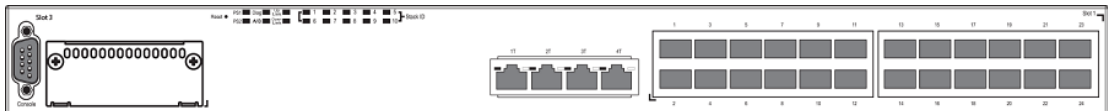

FIGURE 4 Brocade FCX 624S-HPOE front panel



FIGURE 5 Brocade FCX 648S-HPOE front panel

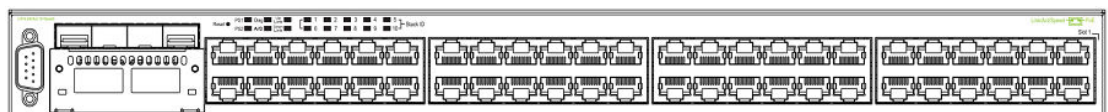

FIGURE 6 Brocade FCX 648S-HPOE rear panel

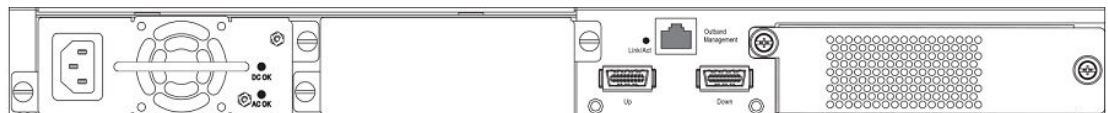

FIGURE 7 Brocade FCX 624-E front panel

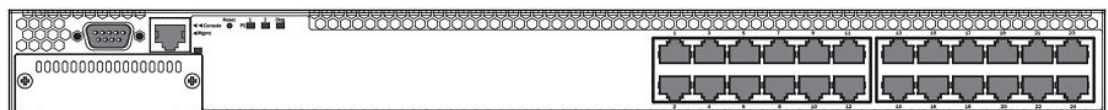

FIGURE 8 Brocade FCX 624-I front panel

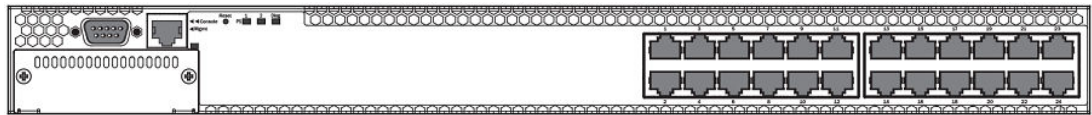

FIGURE 9 Brocade FCX 648-E front panel

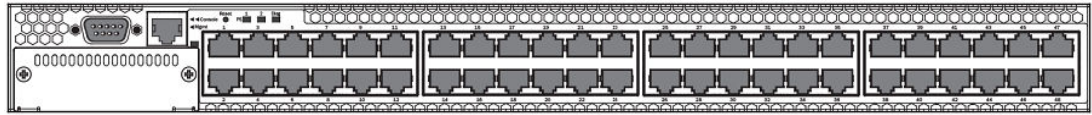

FIGURE 10 Brocade FCX 648-I front panel

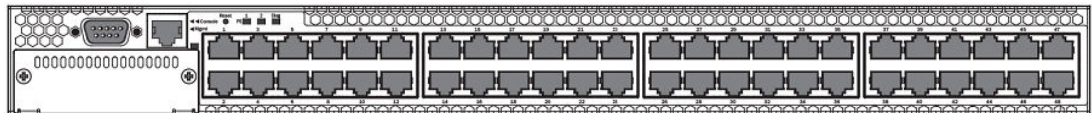
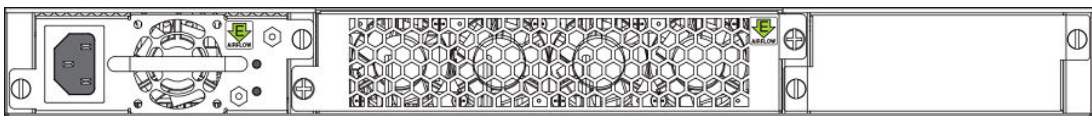

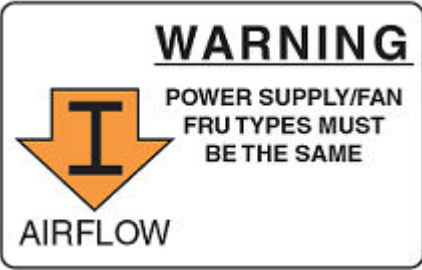

FIGURE 11 Brocade FCX 624-E, FCX 624-I, FCX 648-E, and FCX 648-I rear panels



CAUTION

For the Brocade FCX 624-E, FCX 624-I, FCX 648-E, and FCX 648-I devices, be sure that the airflow direction of the power supply unit matches that of the installed resilient quad-fan fan tray. The power supplies and fan trays are clearly labeled with either a green arrow with an "E", or an orange arrow with an "I".

Device	Label on required power supply	Label on required fan tray
Brocade FCX 624-E and Brocade FCX 648-E		

Device	Label on required power supply	Label on required fan tray
Brocade FCX 624-I and Brocade FCX 648-I		

Control features

Each device front panel includes the following control features:

- Serial management interface (the DB9 port labeled **Console**)
- Out-of-band RJ45 management Interface

Serial management interface (DB9 Console port)

The serial management interface allows you to configure and manage the device using a third-party terminal emulation application on a directly-connected PC. A straight-through EIA or TIA DB9 serial cable (M or F) ships with the device. The serial management interface (the DB9 Console port) is located in the left corner of the front panel.

Out-of-band RJ45 management interface

The out-of-band RJ45 management interface enables you to configure and manage the device using a third-party terminal emulation application on a directly-connected PC.

Network interfaces for Brocade FCX 624S, FCX 648S, FCX 624S-F, FCX 624S-HPOE, and FCX 648S-HPOE

FCX devices contain the following interfaces:

- 10/100/1000 Mbps ports with RJ45 copper connectors
- 100/1000 Mbps ports with mini-GBIC slots for SFP MSA-compliant fiber transceivers
- Optional 2-port 10Gbps Ethernet XFP module
- CX4 stacking ports

NOTE

Brocade recommends that you refer to [Cable specifications](#) on page 65 before connecting a cable to any of the ports.

Network interfaces for Brocade FCX 624-E, FCX 624-I, FCX 648-E, and FCX 648-I

FastIron CX devices contain the following interfaces:

- 10/100/1000 ports with RJ45 copper connectors
- 100/1000 ports with mini-GBIC slots for MSA-compliant SFP transceivers
- Optional 4-port 1Gbps Ethernet SFP module
- Optional 4-port 10Gbps Ethernet SFP+ module

NOTE

Brocade recommends that you refer to [Cable specifications](#) on page 65 before connecting a cable to any of the ports.

FastIron CX 10/100/1000 BASE-T ports

All FastIron CX devices except for the fiber models contain 24 or 48 RJ45 ports that operate at 10 Mbps or 100 Mbps, half or full duplex, or at 1000 Mbps, full duplex. FCX fiber models contain 24 SFP ports. Because all ports support automatic MDI or MDI-X operation, you can use straight-through cables for all network connections to PCs or servers, or to other switches or hubs. In addition, it is ideal and preferred to use straight-through cable for switch-to-switch connections.

Each of these ports supports auto-negotiation, so the optimum transmission mode (half or full duplex), and the data rate (10, 100, or 1000 Mbps) can be selected automatically. If a device connected to one of these ports does not support auto-negotiation, the communication mode of the port can be configured manually.

Combination ports

FCX devices contain four combination ports, which are four Small Form Factor Pluggable (SFP) network interfaces (1F~4F) that are shared with four of the RJ45 ports (ports 1~4). In the default configuration, if an SFP transceiver is installed in a slot and has a valid link on its port, the associated RJ45 port is disabled and cannot be used. The switch can also be configured to force the use of a combination RJ45 port or SFP slot, as required.

NOTE

Brocade FCX 624-E, FCX 624-I, FCX 648-E, and FCX 648-I devices do not ship with SFP ports. You must install the optional SFP module for SFP support.

Slot locations

There are three slot locations on Brocade FCX Series devices: slots 3 and 1 on the front panel and slot 2 on the rear panel.

FIGURE 12 Slot locations on the front panel of Brocade FCX Series devices

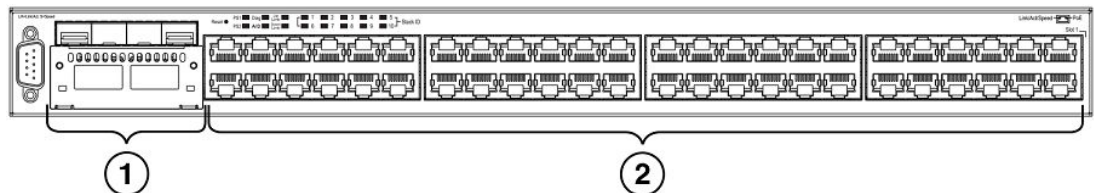

1. Slot 3
2. Slot 1

FIGURE 13 Slot location on the rear panel of Brocade FCX Series devices

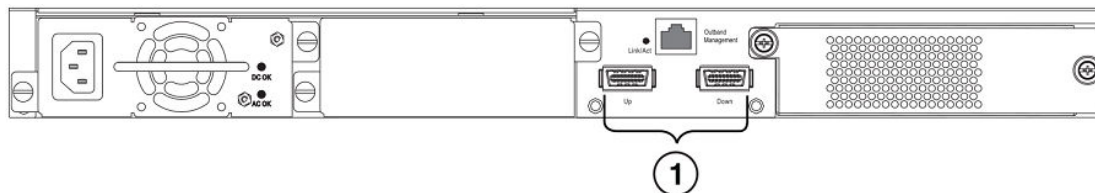

1. Slot 2 (default stacking ports)

Slot designations

The slot designations for FCX models:

TABLE 1 Stack unit slots for FCX stackable devices

Device	Slot 1	Slot 2	Slot 3
Brocade FCX 624S	20 10/100/1000 Mbps ports plus 4 Combo ports (RJ45 ports 1-4, or SFP ports 1F-4F)	2-port 16 Gbps CX4 stacking module on rear panel	2-port 10 Gbps XFP module
Brocade FCX 648S	44 20 10/100/1000 Mbps ports plus 4 Combo ports (RJ45 ports 1-4, or SFP ports 1F-4F)	2-port 16 Gbps CX4 stacking module on rear panel	2-port 10 Gbps XFP module
Brocade FCX 624S-F	20 100/1000 Mbps SFP ports plus 4 Combo ports 10/100/1000 Mbps RJ45 on front panel	2-port 16 Gbps CX4 stacking module on rear panel	2-port 10 Gbps XFP module
Brocade FCX 624-E and Brocade FCX 624-I devices with optional 4-port 1 Gbps SFP module	20 10/100/1000 Mbps RJ45 ports, plus 4-port 1 Gbps SFP module (optional module) combined with the first four 10/100/1000 Mbps RJ45 copper ports (acting as a Combo port).	N/A	N/A
Brocade FCX 648-E and Brocade FCX 648-I devices with optional 4-port 1 Gbps SFP module	44 10/100/1000 Mbps RJ45 ports, plus 4-port 1 Gbps SFP module (optional) combined with the first four 10/100/1000 Mbps RJ45 copper ports (acting as a Combo port).	N/A	N/A
Brocade FCX 624-E and Brocade FCX 624-I devices with optional 4-port 10 Gbps SFP+ module	24 10/100/1000 Mbps RJ45 ports	4-port 10 Gbps SFP+ module on front panel (optional module)	N/A

TABLE 1 Stack unit slots for FCX stackable devices (Continued)

Device	Slot 1	Slot 2	Slot 3
Brocade FCX 648-E and Brocade FCX 648-I devices with optional 4r-port 10 Gbps SFP+ module	48 10/100/1000 Mbps RJ45 ports	4-port 10 Gbps SFP+ module on front panel (optional module)	N/A

SFP interfaces

This section describes the network interfaces supported on FCX devices. For information about supported SFP and SFP+ transceivers, refer to the following Brocade website:

http://www.brocade.com/downloads/documents/data_sheets/product_data_sheets/Optics_DS.pdf

TABLE 2 SFP network interfaces

Interface	Show Media Description
1000Base-BX-D	M-GBXD
1000Base-BX-U	M-GBXU
1000Base-LHA	M-LHA
1000Base-LHB	M-LHB
1000Base-LX	M-LX
1000Base-LH	M-LH
1000Base-SX	M-SX
1000Base-T	C
100Base-T	C**
10Base-T	C**
100Base-FX	M-FX

Optional two-port 10 Gbps XFP uplink module

The Brocade FCX 624S, FCX 648S, FCX 624S-F, FCX 624S-HPOE, and FCX 648S-HPOE devices include a slot on the front panel for a two-port 10 Gbps XFP uplink module. This module operates at 10 Gbps full duplex.

NOTE

The 10 Gbps XFP module is not hot-swappable.

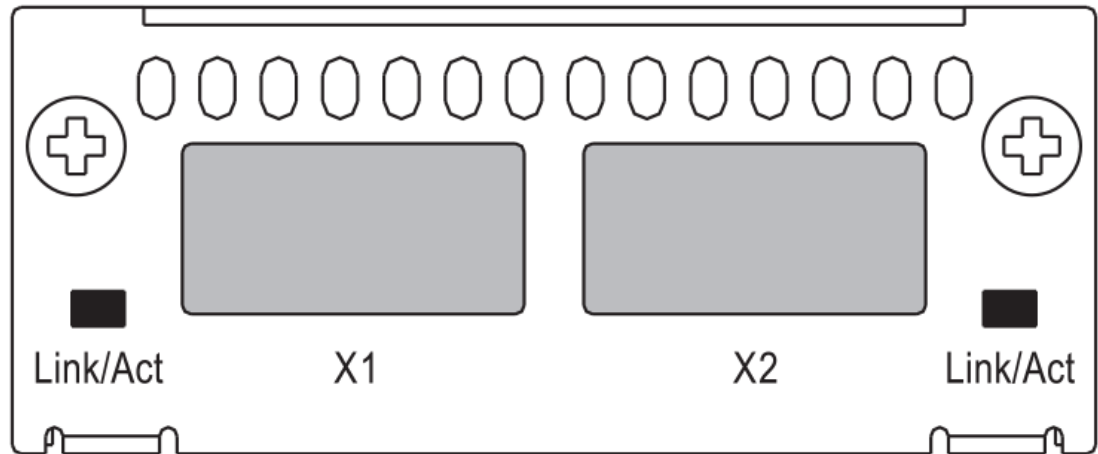
FIGURE 14 Two-port 10 Gbps XFP module**TABLE 3** Two-port 10 Gbps XFP module port status LEDs

LED	Condition	Status
Link or Act LED (Link or Activity)	On or flashing Green	Port has a valid link at 10 Gbps. Flashing indicates activity.
	Off	The link is down.

Optional 4x1G SFP+ and 4x10G SFP+ modules

The Brocade FCX 624-E, FCX 624-I, FCX 648-E, and FCX 648-I devices include a slot on the front panel for a four-port 1 Gbps SFP module, or a four-port 10 Gbps SFP+ module. The 1 Gbps SFP module operates at 1 Gbps full duplex, and the 10 Gbps SFP+ module operates at 10 Gbps full duplex.

FCX-I and FCX-E devices can be used in a homogeneous stack by installing the optional 4-port 10 Gbps SFP+ module, and connecting devices using standard duplex LC cables. These devices cannot be combined in a stack with non-FCX devices. For detailed information about how to configure FCX devices in a homogeneous stack, see the *FastIron Ethernet Switch Stacking Configuration Guide*.

NOTE

The 1 Gbps SFP and 10 Gbps SFP+ modules are not hot-swappable.

FIGURE 15 Four-port 1 Gbps SFP module

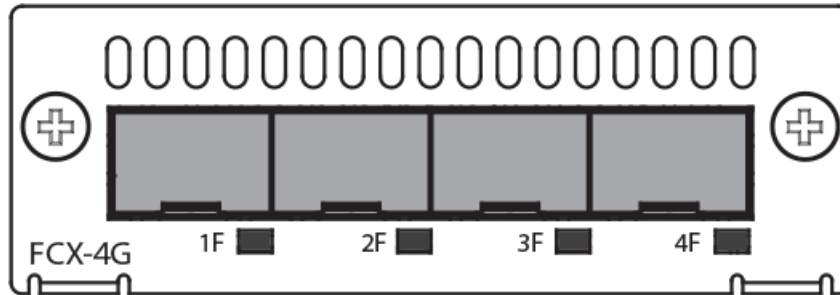

TABLE 4 Four-port 1 Gbps SFP module status LEDs

LED	Condition	Status
Link or Act LED (Link or Activity)	On or flashing Green	Port has a valid link at 1 Gbps. Flashing indicates activity.
	Off	The link is down.

FIGURE 16 Four-port 10 Gbps SFP+ module

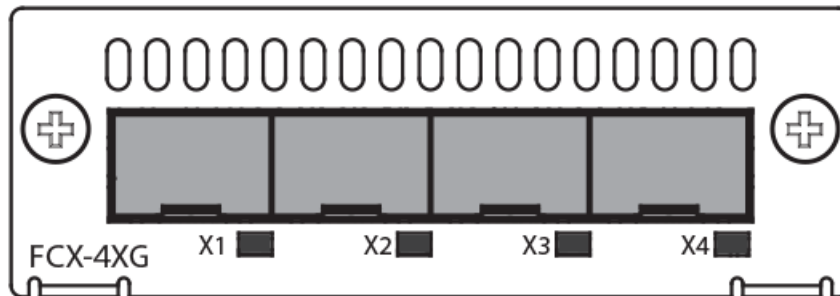

TABLE 5 Four-port 10 Gbps SFP+ module status LEDs

LED	Condition	Status
Link or Act LED (Link or Activity)	On or flashing Green	Port has a valid link at 10 Gbps. Flashing indicates activity.
	Off	The link is down.

NOTE

The two left ports on the SFP+ module do not pass regular Ethernet traffic by default. The **stack disable** CLI command must be configured on these two ports in order for them to pass regular traffic.

16/10 Gbps Ethernet CX4 stacking module

The Brocade FCX 624S, FCX 648S, FCX 624S-F, FCX 624S-HPOE, and FCX 648S-HPOE devices include two 16/10 Gbps Ethernet CX4 ports on the rear panel (the stacking ports). The device can perform data transmission directly through copper links of up to 3 meters.

The Up Link and Down Link LEDs on the front panel indicate operational status. If the Up Link or Down Link LED is on, the port is connected. If the Up Link or Down Link LED is off, no connection exists, or the link is down.

Cable specifications for CX4 stacking ports

The following cable specifications apply to the CX4 stacking ports:

- Support for 802.3ak or 10 Gbps Ethernet CX4 standard and 16 Gbps inter-unit stacking (up to 8 units in a stack)
- Support for cables up to 3 meters in length
- Requires latch-style receptacle or SFF-8470 plug

NOTE

Brocade FCX 624-E, FCX 624-I, FCX 648-E, and FCX 648-I devices can be added to a stack using the first two ports on a four-port 10 Gbps SFP+ module (optional) using standard duplex LC cables.

Optional 2-port 10 Gbps SFP+ uplink module

Feature description for the 2-port 10 Gbps SFP+ module including modified CLI examples

The following Brocade FCX devices include a slot on the front panel for a two-port 10 Gbps SFP+ uplink module. This module operates at 10 Gbps full duplex.

- Brocade FCX 624S
- Brocade FCX 648S
- Brocade FCX 624S-F
- Brocade FCX 624S-HPOE
- Brocade FCX 648S-HPOE

The 2-port 10 Gbps SFP+ uplink module can replace the 2-port XFP module in the fixed slot 3. Port mapping is the same as for the 2x10 XFP with slot 3 and port 1 or 2, for example, 1/3/1 and 1/3/2. Stacking is supported using the **stack default-port** command with the 1/3/1 and 1/3/2 options.

The module is named FCX-2SFPP 2-port 10G Module (2-SFP+) in configuration and output.

NOTE

Reload the device whenever you install or replace the module because the 2x10 SFP+ module is not hot swappable.



CAUTION

Power-down your device before you install or replace a module for safety purposes and to avoid instability due to a delay in power cycling.

FIGURE 17 Two-port 10 Gbps SFP+ module

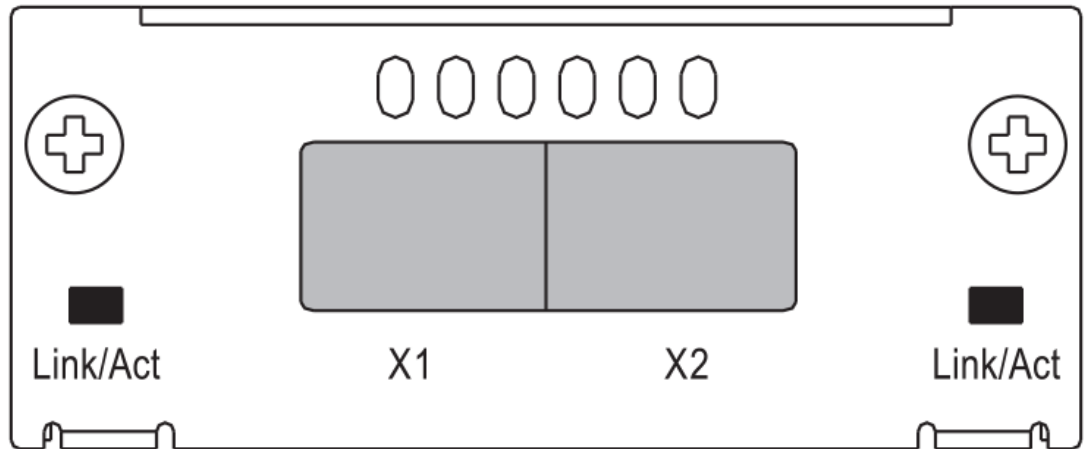

TABLE 6 10 Gbps SFP+ module port status LEDs

LED	Condition	Status
Link or Act LED (Link or Activity)	On or flashing green	Port has a valid link at 10 Gbps. Flashing indicates activity.
	Off	The port is down.

Modified CLI examples for the 2-port 10 Gbps SFP+ module

The following sample output from the **show module** command displays an entry for the 2-port 10G SFP+ module.

```
device# show module
Module
U1:M1 FCX-48GS POE 48-port Management Module      Status Ports Starting MAC
U1:M2 FCX-2XGC 2-port 16G Module (2-CX4)         OK      48      0024.38c9.4d00
U1:M3 FCX-2SFPP 2-port 10G Module (2-SFP+)       OK      2       0024.38c9.4d31
U1:M3 FCX-2SFPP 2-port 10G Module (2-SFP+)       OK      2       0024.38c9.4d33
```

The following sample output from the **show version** command shows that the 2-port 10G SFP+ module is in slot 3.

```
device# show version
Copyright (c) 1996-2011 Brocade Communications Systems, Inc.
UNIT 1: compiled on Oct 18 2012 at 16:01:04 labeled as FCXS07300b1
(5373912 bytes) from Primary FCXS07300b1.bin
SW: Version 07.3.00b1T7f1
Boot-Monitor Image size = 370663, Version:07.3.00T7f5 (grz07300b1)
HW: Stackable FCX648S-HPOE-PREM (PROM-TYPE FCX-ADV-U)
=====
UNIT 1: SL 1: FCX-48GS POE 48-port Management Module
Serial #: BCYXXXXXXXXX
License: BASE_SOFT PACKAGE (LID: deaHHJihFNb)
P-ENGINE 0: type DB90, rev 01
P-ENGINE 1: type DB90, rev 01
PROM-TYPE: FCX-ADV-U
=====
UNIT 1: SL 2: FCX-2XGC 2-port 16G Module (2-CX4)
=====
UNIT 1: SL 3: FCX-2SFPP 2-port 10G Module (2-SFP+)
=====
800 MHz Power PC processor 8544E (version 0021/0022) 400 MHz bus
65536 KB flash memory
256 MB DRAM
STACKID 1 system uptime is 2 days 10 minutes 24 seconds
The system : started=warm start reloaded=by "reload"
```

The following is sample output of the **show running-config** command.

```
device# show running-config
!
Startup-config data location is flash memory
!
Startup configuration:
!
ver 07.3.00a001T7f1
!
stack unit 1
  module 1 fcx-48-poe-port-management-module
  module 2 fcx-cx4-2-port-16g-module
  module 3 fcx-sfpp-2-port-10g-module
!
```

The following is sample output of the **show media** and **show optic** commands with some configuration.

```
device# show media
1/1/1:C 1/1/2:C 1/1/3:C 1/1/4:C 1/1/5:C 1/1/6:C 1/1/7:C 1/1/8:C
1/1/9:C 1/1/10:C 1/1/11:C 1/1/12:C 1/1/13:C 1/1/14:C 1/1/15:C 1/1/16:C
1/1/17:C 1/1/18:C 1/1/19:C 1/1/20:C 1/1/21:C 1/1/22:C 1/1/23:C 1/1/24:C
1/1/25:C 1/1/26:C 1/1/27:C 1/1/28:C 1/1/29:C 1/1/30:C 1/1/31:C 1/1/32:C
1/1/33:C 1/1/34:C 1/1/35:C 1/1/36:C 1/1/37:C 1/1/38:C 1/1/39:C 1/1/40:C
1/1/41:C 1/1/42:C 1/1/43:C 1/1/44:C 1/1/45:C 1/1/46:C 1/1/47:C 1/1/48:C
1/2/1:XG-CX4 1/2/2:XG-CX4
1/3/1:XG-SR 1/3/2:XG-SR
device# show media e 1/3/1
Port 1/3/1: Type : 10G XG-SR(SFP +)
Vendor: Brocade Version: 1
Part# : PLRXPLSCS4371 Serial#: CXXXXXXXXX
device(config)# op 1
Enable optical monitoring and set alarm/warn interval to 1 minute(s)
```

Specifying a port address

```
device(config)# show optic 1/3/1
  Port  Temperature  Tx Power  Rx Power  Tx Bias Current
+-----+-----+-----+-----+-----+
1/3/1   32.7421 C  -002.3195 dBm -002.5947 dBm  6.212 mA
        Normal      Normal      Normal      Normal
device# show media e 1/3/1
Port 1/3/1: Type : 10G XG-ER(SFP +)
        Vendor: BROCADE      Version: A
        Part# : 57-0000085-01  Serial#: XXXXXXXXXXXXXXXX
device# show media e 1/3/2
Port 1/3/2: Type : 10G XG-USR (SFP +)
        Vendor: BROCADE      Version: A
        Part# : 57-1000130-01  Serial#: XXXXXXXXXXXXXXXX
device# show media
1/1/1:C 1/1/2:C 1/1/3:C 1/1/4:C 1/1/5:C 1/1/6:C 1/1/7:C 1/1/8:C
1/1/9:C 1/1/10:C 1/1/11:C 1/1/12:C 1/1/13:C 1/1/14:C 1/1/15:C 1/1/16:C
1/1/17:C 1/1/18:C 1/1/19:C 1/1/20:C 1/1/21:C 1/1/22:C 1/1/23:C 1/1/24:C
1/1/25:C 1/1/26:C 1/1/27:C 1/1/28:C 1/1/29:C 1/1/30:C 1/1/31:C 1/1/32:C
1/1/33:C 1/1/34:C 1/1/35:C 1/1/36:C 1/1/37:C 1/1/38:C 1/1/39:C 1/1/40:C
1/1/41:C 1/1/42:C 1/1/43:C 1/1/44:C 1/1/45:C 1/1/46:C 1/1/47:C 1/1/48:C
1/2/1:XG-CX4 1/2/2:XG-CX4
1/3/1:XG-ER 1/3/2:XG-USR
```

Specifying a port address

You can specify a port address for a data port, stacking port, or a management port.

Specifying a data port

The port address format is stack unit/slot/port, where:

- *stack unit*--Specifies the stack unit ID. Range is from 1 to 8. If the device is not part of a stack, the stack unit ID is 1.
- *slot*--Specifies the slot number. Can be 1 or 3.
- *port*--Specifies the port number in the slot. Range is from 1 to 24 (24-port models) or 1 to 48 (48-port models).

This example indicates it is Stack Unit 1:

```
Brocade(config)# interface ethernet 1/1/2
```

Specifying a stacking port

The port address format is stack unit/slot/port, where:

- *stack unit*--Specifies the stack unit ID. Range is from 1 to 8.
- *slot*--Specifies the slot number. Default stacking ports are in slot 2 (FCX S/S-F).
- *port*--Specifies the port number in the slot. Default stacking ports in slot 2 are ports 1 and 2.

This example shows how to specify port 2 in slot 2 of unit 3 in a stack:

```
Brocade(config)# interface ethernet 3/2/2
```

Specifying a management port

The management port number is always 1. This example shows how to specify the management port:

```
Brocade(config)# interface management 1
```

Port, system, and power status LEDs for Brocade FCX 624S, FCX 648S, FCX 624S-F, FCX 624S-HPOE, and FCX 648S-HPOE

FCX switches include a display panel for key system and port indicators that simplifies installation and network troubleshooting. The LEDs are located on the front panel for easy viewing.

FIGURE 18 Port status LEDs

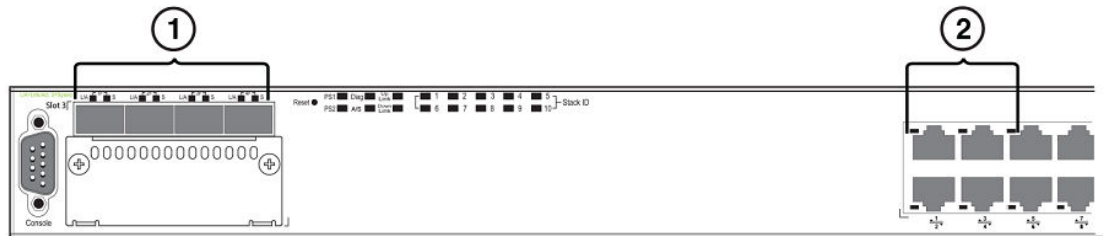

1. Port status LEDs
2. Port status LEDs

TABLE 7 Port status LEDs

LED	Condition	Status
Ethernet(1~24/48) Link or Activity or Speed	On/Flashing Green	The port has established a valid link at 1000 Mbps. Flashing indicates the port is transmitting and receiving user packets.
	On/Flashing Amber	The port has established a valid link at 10 or 100 Mbps. Flashing indicates the port is transmitting and receiving user packets.
	Off	A link is not established with a remote port.
HPOE(1~24/48)	On Green	The port is providing HPOE power to a connected device.
	Off	The port is not providing HPOE power.
SFP(1F~4F) Link or Activity	On/Flashing Green	The SFP port has established a valid link. Flashing indicates the port is transmitting and receiving user packets.
	Off	A link is not established with a remote port.
SFP(1F~4F) Speed	On Green	The SFP port is operating at 1000 Mbps.
	On Amber	The SFP port is operating at 100 Mbps.

TABLE 7 Port status LEDs

LED	Condition	Status
	Off	A link is not established with a remote port.

FIGURE 19 System status LEDs

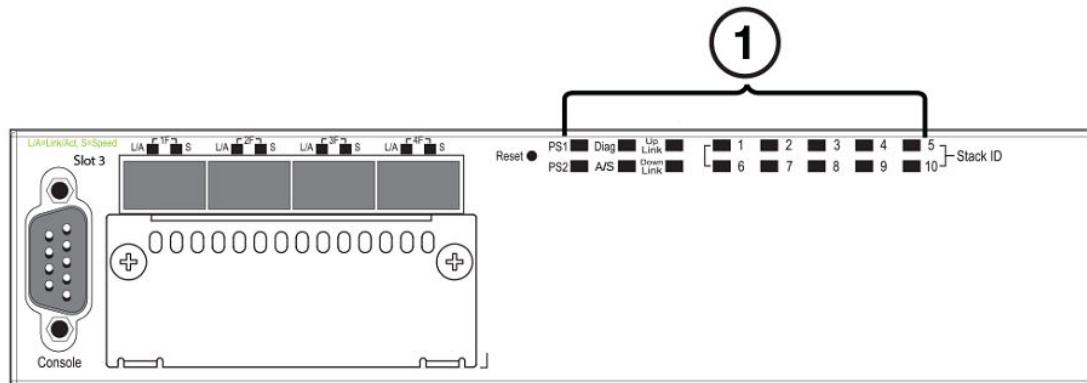

1. System status LEDs

TABLE 8 System status LEDs

LED	Condition	Status
PS1 PS2 (Power Supply Status)	Green	Power supply is operating normally.
	Amber	Power supply fault.
	Off	Power off or failure.
Diag (Diagnostic)	Flashing Green	System self-diagnostic test in progress.
	Green	System self-diagnostic test successfully completed.
	Amber	System self-diagnostic test has detected a fault. (Blower, thermal or any interface fault.)
A or S (Active or Standby)	Green	The device is the Active controller. If this LED is flashing green, the system is initializing.
	Amber	Indicates the device is the Standby controller.
	Off	Device is operating as a stack member, or is in standalone mode.
Up Link or Down Link (Stacking uplink or downlink port status)	Green	Uplink is operating normally.
	Off	Uplink has failed or there is no link.

TABLE 8 System status LEDs

LED	Condition	Status
Stack ID (1-8)	Green	Indicates the device stack ID.

FIGURE 20 Power status LEDs

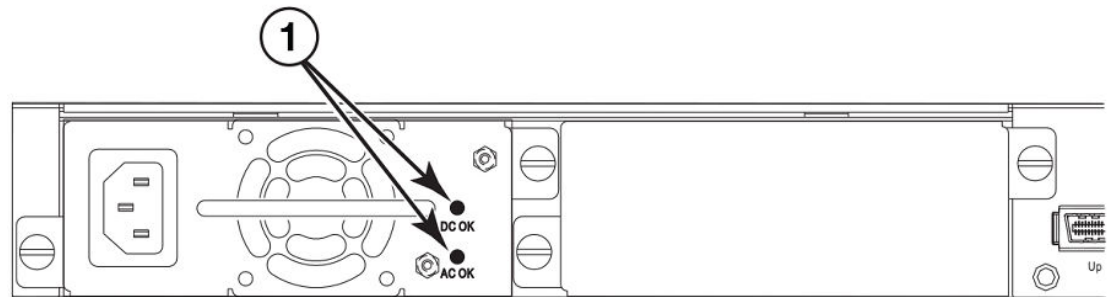

1. Power status LEDs

TABLE 9 Power status LEDs

LED	Condition	Status
DC OK	Green	DC output ok
	Red	DC output fail
AC OK	Green	AC input ok
	Off	AC input fail

NOTE

Both "AC OK" and "DC OK" LEDs must be green for the device to function normally.

TABLE 10 Switch status for two installed power supply units

State	LED	PSU1	PSU2	Switch Status	Load Sharing	HPOE Budget(HPOE models only)
Four Green PSU LEDs	AC OK	Green	Green	Running	Yes	820W
	DC OK	Green	Green			
Single Red 'DC OK' LED	AC OK	Green	Green	Running	No	410W
	DC OK	Green	Red			
Both 'DC OK' LEDs Red	AC OK	Green	Green	Failure	No	None
	DC OK	Red	Red			

TABLE 10 Switch status for two installed power supply units (Continued)

State	LED	PSU1	PSU2	Switch Status	Load Sharing	HPOE Budget(HPOE models only)
One PSU with both 'AC OK' 'DC OK' LEDs Off	AC OK	Green	Off	Running	No	410W
	DC OK	Green	Off			
'DC OK' LEDs Red and Off	AC OK	Green	Off	Failure	No	None
	DC OK	Red	Off			
All 'AC OK' LEDs Off	AC OK	Off	Off	Power Off or Failure	No	None
	DC OK	Off	Off			

NOTE

When two 620W power supplies are installed in an HPOE system that has no load or light load on the POE function, one of two power supplies may have its "DC OK" LED light red. There is no fault in the power supply or the system and the switch is functioning normally. The LED will turn to green automatically once the load is increased over the minimum load requirement. In configurations with a single power supply installed the "DC OK" LED will light green in a no-load or light-load condition.

Port, system, and power status LEDs for Brocade FCX 624-E, FCX 624-I, FCX 648-E, and FCX 648-I

FCX switches include a display panel for key system and port indicators that simplifies installation and network troubleshooting. The LEDs are located on the front panel for easy viewing.

FIGURE 21 Port status LEDs

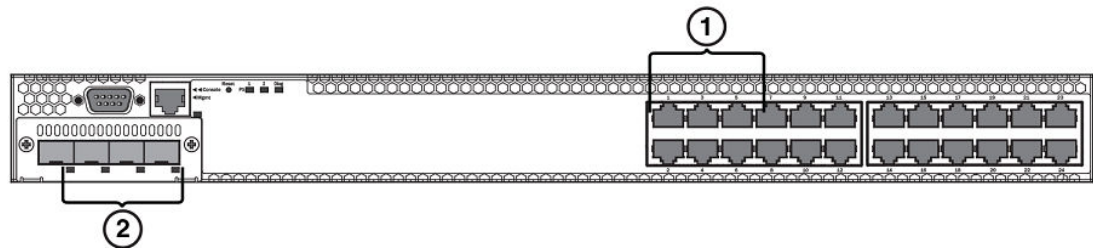

1. Port status LEDs
2. SFP or SFP+ port status LEDs

TABLE 11 Port status LEDs

LED	Condition	Status
Ethernet(1~24/48) Link or Activity or Speed	On/Flashing Green	The port has established a valid link at 10/100/1000 Mbps. Flashing indicates the port is transmitting and receiving user packets.
	Off	A link is not established with a remote port.

TABLE 11 Port status LEDs (Continued)

LED	Condition	Status
SFP(1F~4F) Link or Activity	On/Flashing Green	The SFP port has established a valid 100/1000 Mbps link. Flashing indicates the port is transmitting and receiving user packets.
	Off	A link is not established with a remote port.
SFP+(1F~4F) Link or Activity	On/Flashing Green	The SFP+ port has established a valid 10 Gbps link. Flashing indicates the port is transmitting and receiving user packets.
	Off	A link is not established with a remote port.

FIGURE 22 System status LEDs

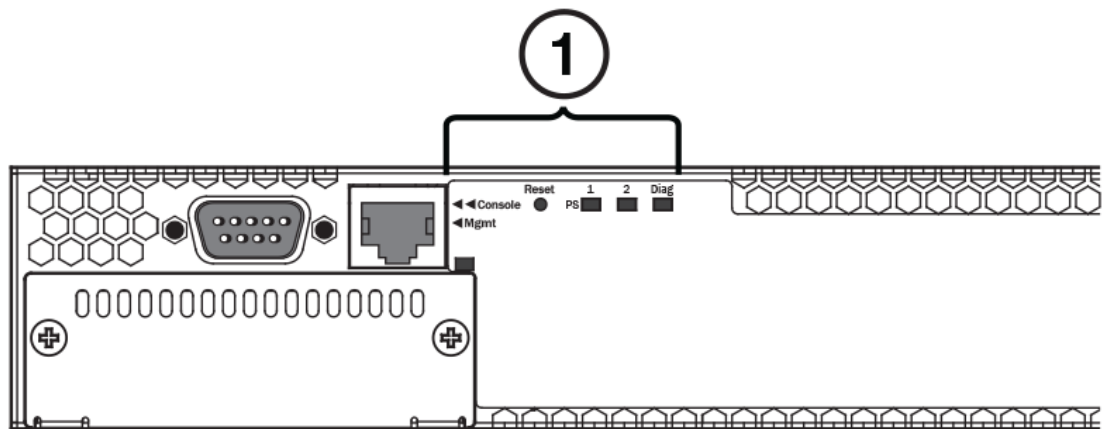

1. System status LEDs

TABLE 12 System status LEDs

LED	Condition	Status
PS1 PS2 (Power Supply Status)	Green	Power supply is operating normally. It is installed properly and the power cord is attached to a power source.
	Amber	Power supply fault. The power supply may not be installed properly.
	Off	Power off or failure.
Diag (Diagnostic)	Flashing Green	System self-diagnostic test in progress.
	Green	System self-diagnostic test successfully completed.
	Amber	System self-diagnostic test has detected a fault. (Blower, thermal or any interface fault.)

TABLE 12 System status LEDs (Continued)

LED	Condition	Status
Out-of-band ManagementLink or Activity	On/Flashing Green	The port has established a valid link at 10/100/1000 Mbps. Flashing indicates the port is transmitting and receiving user packets.
	Off	A link is not established with a remote port.

FIGURE 23 Power status LEDs

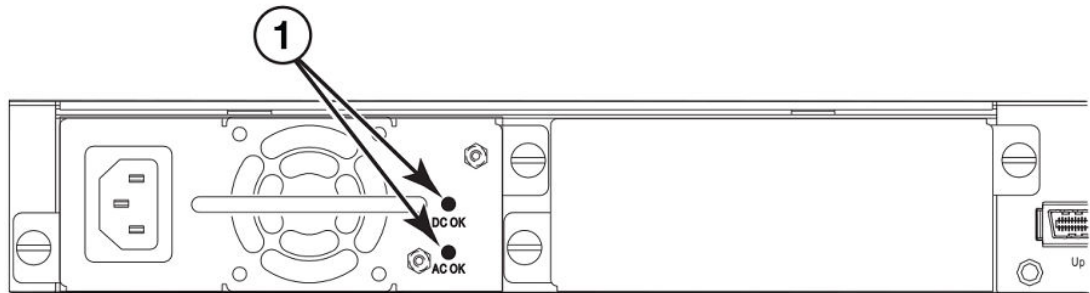

1. Power status LEDs

TABLE 13 Power status LEDs

LED	Condition	Status
DC OK	Green	DC output ok
	Red	DC output fail
AC OK	Green	AC input ok
	Off	AC input fail

NOTE

Both "AC OK" and "DC OK" LEDs must be green for the device to function normally.

TABLE 14 Switch status for two installed power supply units

State	LED	PSU1	PSU2	Switch Status	Redundancy
Four Green PSU LEDs	AC OK	Green	Green	Running	Yes
	DC OK	Green	Green		
Single Red 'DC OK' LED	AC OK	Green	Green	Running	No
	DC OK	Green	Red		
Both 'DC OK' LEDs Red	AC OK	Green	Green	Failure	No

TABLE 14 Switch status for two installed power supply units (Continued)

State	LED	PSU1	PSU2	Switch Status	Redundancy
	DC OK	Red	Red		
One PSU with both 'AC OK' 'DC OK' LEDs Off	AC OK	Green	Off	Running	No
	DC OK	Green	Off		
'DC OK' LEDs Red and Off	AC OK	Green	Off	Failure	No
	DC OK	Red	Off		
All 'AC OK' LEDs Off	AC OK	Off	Off	Power Off or Failure	No
	DC OK	Off	Off		

Power supplies

The device has two power receptacles on the rear panel. Each device ships with one power supply installed. Brocade FCX 624S, FCX 648S, FCX 624S-F, FCX 624-E, FCX 624-I, FCX 648-E and FCX 648-I devices use a 210W PSU. Brocade FCX 624S-HPOE and Brocade FCX 648S-HPOE devices use a 620W PSU.

Each power supply has one standard power receptacle for the AC power cable, and AC and DC status LEDs for easy monitoring and troubleshooting.

A secondary power supply can be installed to provide backup power in case of a failure and for load-balancing when both power supplies are operational. Load-balancing gives the power supplies a longer life span. Both 210W and 620W PSUs are hot-swappable.

For instructions on installing and replacing a power supply refer to [Installing and replacing a power supply unit](#) on page 50.

FIGURE 24 Brocade FCX 624-E, FCX 624-I, FCX 648-E, and FCX 648-I AC power supply receptacle

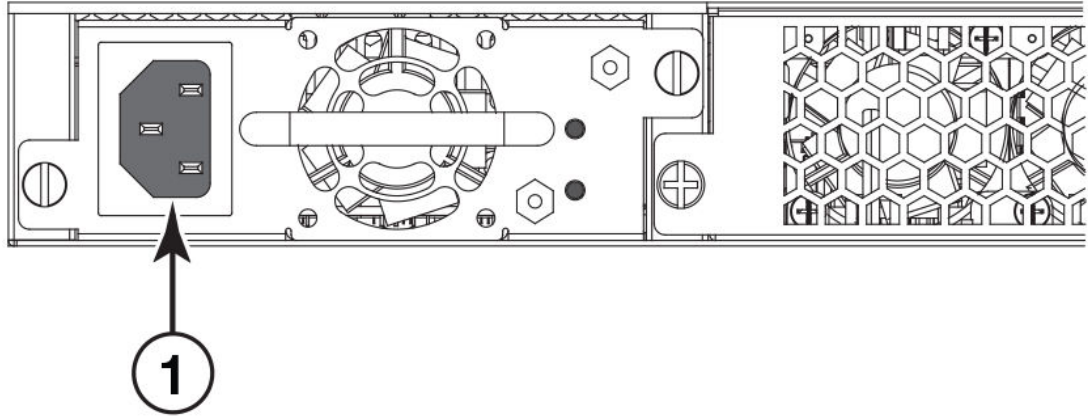

1. AC power receptacle

Power supply unit operation

When only one PSU is installed, both "AC OK" and "DC OK" LEDs on the installed PSU must be green for the FCX device to function normally.

When two PSUs are installed, both "AC OK" and "DC OK" LEDs for one of the installed PSUs must be green for the FCX device to function normally.

HPOE and HPOE + power supplies

Brocade FCX 624S-HPOE and Brocade FCX 648S-HPOE devices use a 620W PSU. When one PSU is powering the switch, the HPOE budget is 410W. If both PSUs are installed and powering the switch, each PSU provides 410W to the switch, increasing the HPOE budget to 820W.

Installing the FCX Switch

- [Unpacking the device](#)..... 33
- [Installation tasks](#)..... 34
- [Installation precautions](#)..... 35
- [Preparing the installation site](#)..... 36
- [Connecting devices in a traditional stack](#)..... 41
- [Powering on the system](#)..... 48
- [Attaching a PC or terminal](#)..... 49
- [Installing and replacing a power supply unit](#)..... 50
- [Installing or replacing fan trays](#)..... 52
- [Installing an optional module](#) 53



CAUTION

The procedures in this manual are intended for qualified service personnel.



CAUTION

Before beginning the installation, see the precautions in [Power precautions](#) on page 35.

Unpacking the device

FCX devices ship with all of the items listed below. Verify the contents of your shipping container. If any items are missing, please contact the place of purchase.

Package contents

The following items are included in your shipping carton:

- FCX device
- 115V AC power cable (for AC sourced devices)
- FCX-S and FCX-F devices ship with a .5M CX-4 stacking cable
- Rack mount brackets
- Warranty card
- A straight-through EIA or TIA DB-9 serial cable (F/F). The serial cable can be ordered separately from Brocade Communication Systems, Inc. If you prefer to build your own cable, see the pinout information in [Attaching a PC or terminal](#) on page 49.

General requirements

To manage the system, you need a management station, such as a PC running a terminal emulation application. Connect the management station to the Console serial port on the switch.

Use the serial connection to perform basic configuration tasks, including assigning an IP address and network mask to the system. This information is required to manage the system using the Brocade Network Advisor or using the CLI through Telnet.

Installation tasks

Follow the steps listed in this section to install your device. Details for each of these steps are provided on the pages indicated.

TABLE 15 Installation tasks

Task Number	Task	Where to Find More Information
1	Ensure that the physical environment that will host the device has the proper cabling and ventilation.	Preparing the installation site on page 36
2	Install any required optional modules into the switch.	Powering on the system on page 48
3	Install the Brocade device on a desktop, in an equipment rack.	Installing the device on page 37
4	Once the device is physically installed, plug the device into a nearby power source that adheres to the regulatory requirements outlined in this manual.	Powering on the system on page 48
5	Attach a terminal or PC to the Brocade device. This will enable you to configure the device through the Command Line Interface (CLI).	Attaching a PC or terminal on page 49
6	No default password is assigned to the CLI. For additional access security, assign a password.	Assigning permanent passwords on page 59
7	Before attaching equipment to the device, you need to configure an interface IP address to the subnet on which it will be located. Initial IP address configuration is performed using the CLI with a direct serial connection.	Configuring IP addresses on page 61
8	Once you power on the device and assign IP addresses, the system is ready to accept network equipment.	Installing the device on page 37
9	Test IP connectivity to other devices by pinging them and tracing routes.	Testing connectivity on page 71
10	Continue configuring the device using the CLI. You can also use Brocade Network Advisor to manage the device.	<i>Brocade Network Advisor</i>
11	Secure access to the device.	<i>FastIron Ethernet Switch Security Guide</i>

Installation precautions

Follow all precautions when installing a Brocade device.

General precautions



CAUTION

All fiber-optic interfaces use Class 1 lasers.



CAUTION

Do not install the device in an environment where the operating ambient temperature might exceed 40 °C (104 °F).



CAUTION

Make sure the air flow around the front and sides of the device is not restricted.



CAUTION

Never leave tools inside the device.

Lifting precautions



CAUTION

Make sure the rack or cabinet housing the device is adequately secured to prevent it from becoming unstable or falling over.

Power precautions



CAUTION

Use a separate branch circuit for each AC power cord, which provides redundancy in case one of the circuits fails.



CAUTION

To avoid high voltage shock, do not open the device while the power is on.



CAUTION

Ensure that the device does not overload the power circuits, wiring, and over-current protection. To determine the possibility of overloading the supply circuits, add the ampere (amp) ratings of all devices installed on the same circuit as the device. Compare this total with the rating limit for the circuit. The maximum ampere ratings are usually printed on the devices near the input power connectors.



CAUTION

Disconnect the power cord from all power sources to completely remove power from the device.



CAUTION

Before plugging a cable to any port, be sure to discharge any static charge stored on the cable by touching the electrical contacts to ground surface.



CAUTION

If the installation requires a different power cord than the one supplied with the device, make sure you use a power cord displaying the mark of the safety agency that defines the regulations for power cords in your country. The mark is your assurance that the power cord can be used safely with the device.

Preparing the installation site

Cabling infrastructure

Ensure that the proper cabling is installed at the site. Refer to [Hardware specifications](#) on page 85 or www.brocade.com for a summary of supported cabling types and their specifications.

Installation location

Before installing the device, plan its location and orientation relative to other devices and equipment. Switches can be mounted in a standard 19-inch equipment rack that meets EIA-310D standards, or on a flat surface. Be sure to follow the guidelines below when choosing a location.

The site should meet the following requirements:

- Maintain temperatures within 0 to 40 °C (32 to 104 °F) and humidity levels within 5% to 95%, non-condensing.
- Allow a minimum of 3 in. of space between the sides and the back of the device and walls or other obstructions for proper air flow.

- Allow at least 3 in. of space at the front and back of the device for the twisted-pair, fiber-optic, and power cabling.
- Be accessible for installing, cabling and maintaining the devices.
- Allow the status LEDs to be clearly visible.
- Allow for twisted-pair cable to be always routed away from power lines, fluorescent lighting fixtures and other sources of electrical interference, such as radios and transmitters.
- Allow for the unit to be connected to a separate grounded power outlet that provides 110 to 240 VAC, 50 to 60 Hz, is within 2 m (6.6 feet) of each device and is powered from an independent circuit breaker. As with any equipment, a filter or surge suppressor is recommended.

Installing the device

You can install Brocade devices on a desktop or in an equipment rack.



CAUTION

Make sure the rack or cabinet housing the device is adequately secured to prevent it from becoming unstable or falling over.

Desktop installation

FIGURE 25 Attaching the adhesive feet

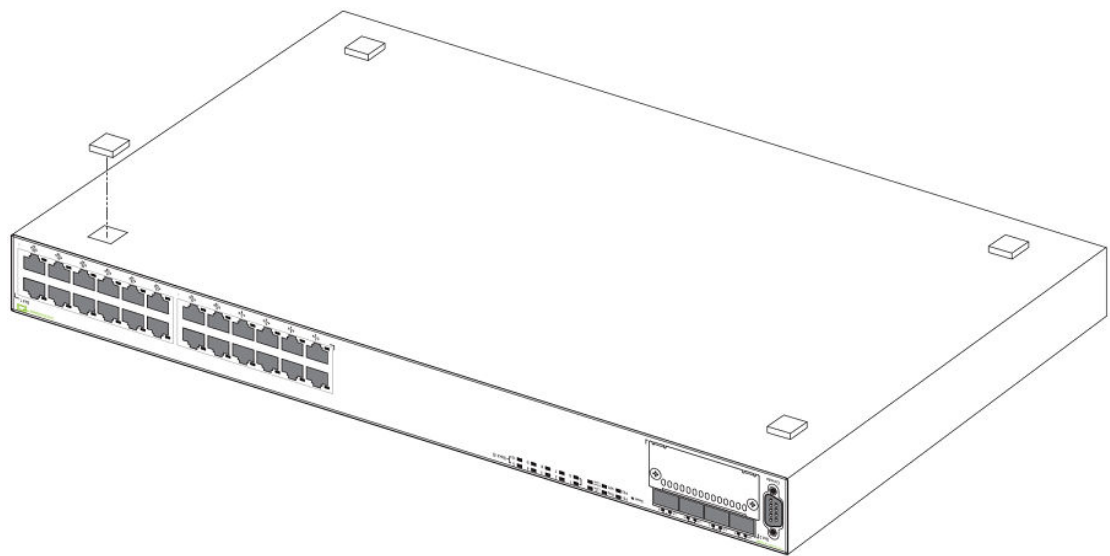

1. Attach the four adhesive feet to the bottom of the first switch.
2. Set the device on a flat desktop, table, or shelf near an AC power source. Make sure that adequate ventilation is provided for the system. A 3 inch clearance is recommended on each side.
3. If installing a single switch only, refer to [Powering on the system](#) on page 48.
4. If installing multiple switches, attach the adhesive feet to each one. Place each device squarely on top of the one below, in any order.

Rack mount installation

NOTE

You need a #2 Phillips screwdriver for installation.

Before mounting the switch in a rack, pay particular attention to the following factors:

- Temperature: Since the temperature within a rack assembly may be higher than the ambient room temperature, check that the rack-environment temperature is within the specified operating temperature range.
- Mechanical loading: Do not place any equipment on top of a rack-mounted unit.
- Circuit overloading: Be sure that the supply circuit to the rack assembly is not overloaded.
- Grounding: Rack-mounted equipment should be properly grounded. Particular attention should be given to supply connections other than direct connections to the mains.

Use the following steps to mount devices in rack.

1. Remove the rack mount kit from the shipping carton. The kit contains two L-shaped mounting brackets and mounting screws.
2. Attach the mounting brackets to the sides of the device.

NOTE

FCX624-E, FCX624-I, FCX648-E, and FCX648-I device brackets are mounted using three screws.

FIGURE 26 Attaching the brackets for the Brocade FCX 624S, FCX 648S, FCX 624S-F, FCX 624S-HPOE, and FCX 648S-HPOE devices

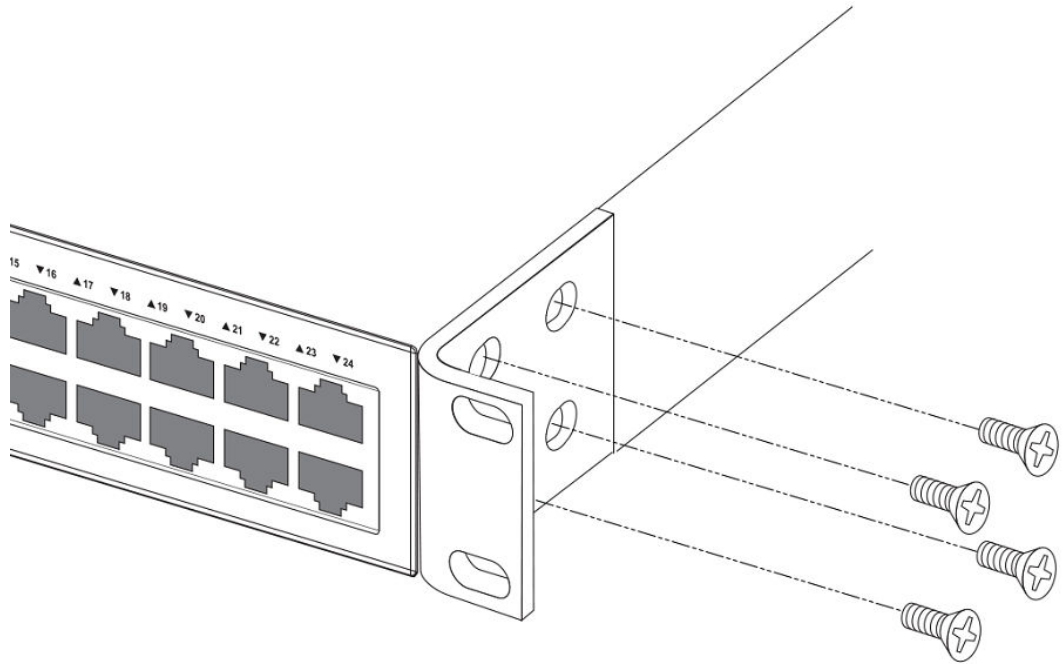
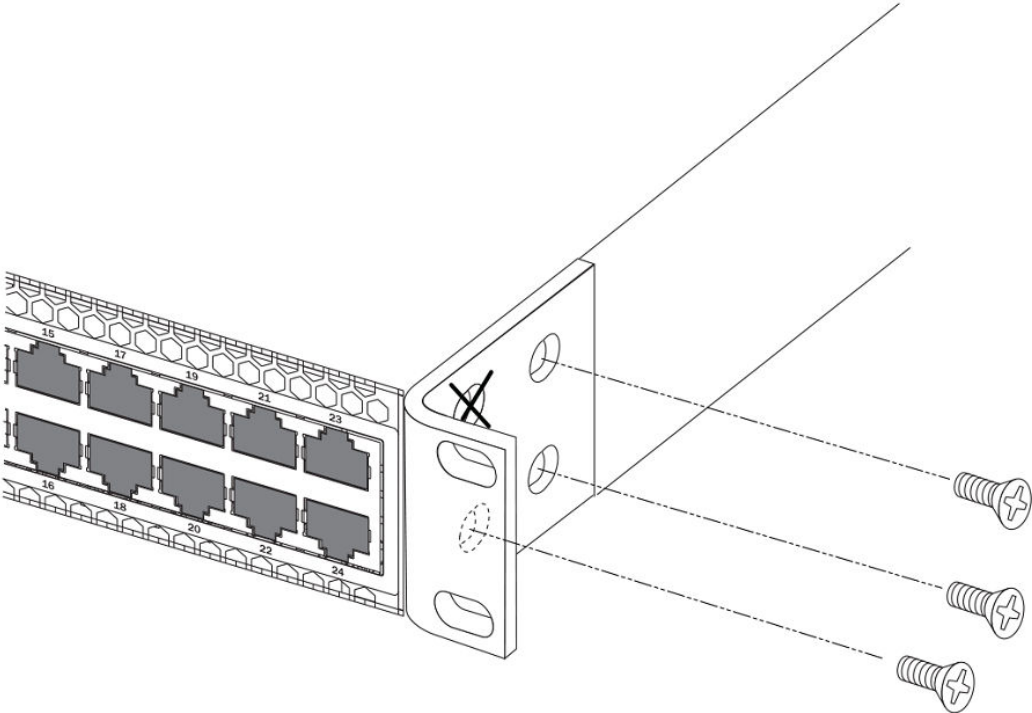

FIGURE 27 Attaching the brackets for the FCX624-E, FCX624-I, FCX648-E, and FCX648-I devices

Installing the FCX Switch



3. Attach the device in the rack.

FIGURE 28 Installing the device in a rack

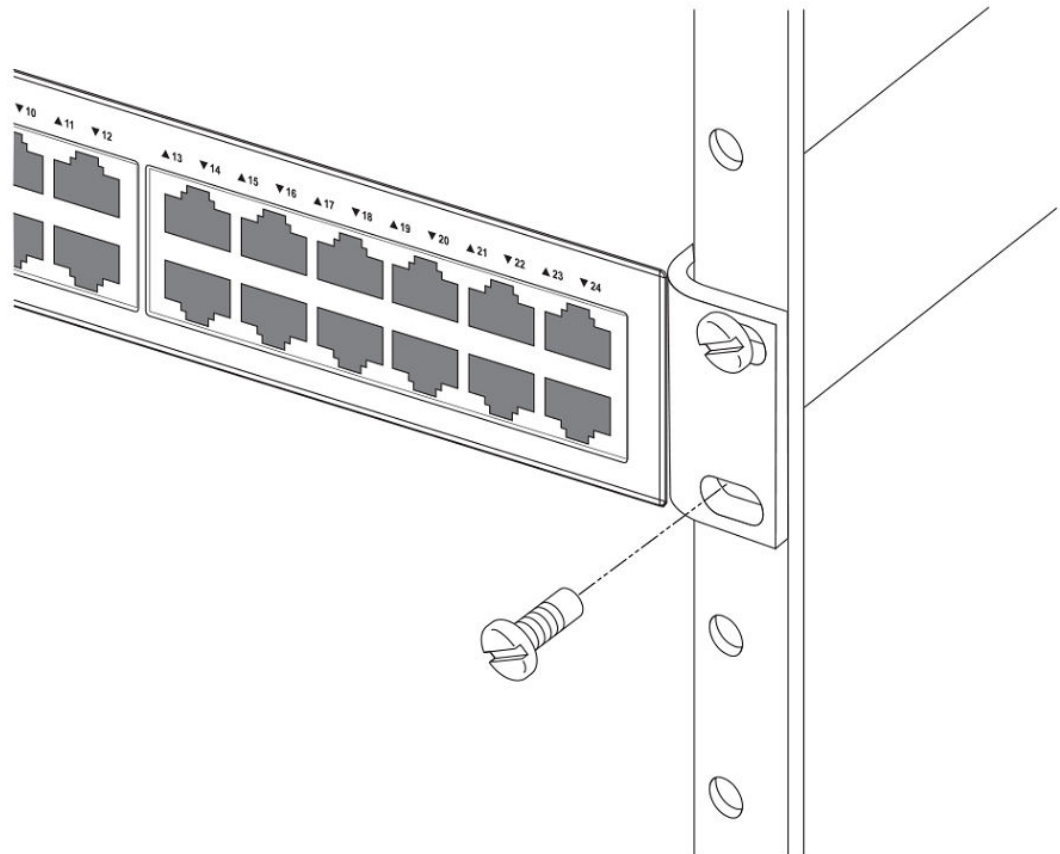

4. If installing a single switch only, proceed to [Powering on the system](#) on page 48.
5. If installing multiple switches, mount them in the rack, one below the other, in any order.

Connecting devices in a traditional stack

Brocade FCX Series devices can operate as standalone devices and also as members of traditional stacks. A stack is a group of devices--Brocade stackable units and their connected stacking links--that are connected so that the stack is managed as a single entity.

A traditional stack contains devices from only one model in a product family. A traditional stack can contain FCX S, FCX S-F, FCS E, and FCX I devices.

Stacking ports

This section summarizes the default stacking ports and the ports that can be used as stacking ports on Brocade FCX Series devices. Default stacking ports have the capability to accept special stacking packets during a CLI-initiated command sequence of the Secure Setup utility. Stacking ports can also be used as data ports.

The default stacking ports on FCX S/S-F devices are the ports in the 16/10 Gbps CX4 stacking module on the rear panel. The default stacking ports on the FCX E/I devices are the first two ports in the four-port 10 Gbps SFP+ module on the front panel.

Refer to the table below for the list of supported XFP transceivers (for stacking and non-stacking FCX models) and supported SFP and SFP+ transceivers.

TABLE 16 Stacking ports on Brocade FCX Series devices

	Panel/slot	Ports	Stacking ports		Data ports	
			Default stacking	Can be data ports	Default data	Can be stacking ports
FCX S/S-F						
16/10 Gbps CX4 stacking module	Rear/2	1,2	Yes: 1, 2	Yes		
2-port 10 Gbps XFP module	Front/3	1,2			Yes: 1, 2	Yes: 1, 2
FCX E/I						

TABLE 16 Stacking ports on Brocade FCX Series devices

Panel/slot	Ports	Stacking ports		Data ports	
		Default stacking	Can be data ports	Default data	Can be stacking ports
4-port 10 Gbps SFP+ module	Front/2	1-4	Yes: 1, 2	Yes	Yes: 3, 4

FIGURE 29 16/10 Gbps CX4 stacking module on the rear panel of FCX S/S-F devices

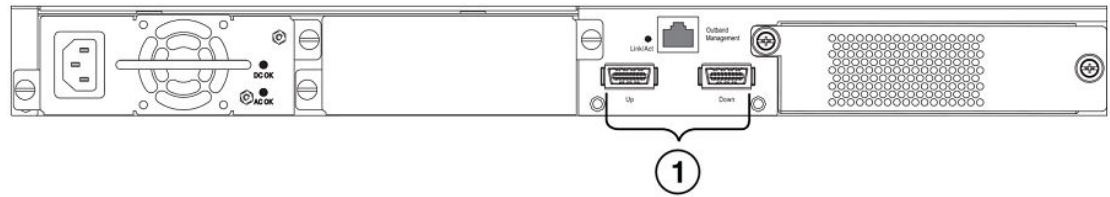

1. 16/10 Gbps CX4 stacking ports

FIGURE 30 Two-port 10 Gbps XFP module on the front panel of FCX S/S-F devices

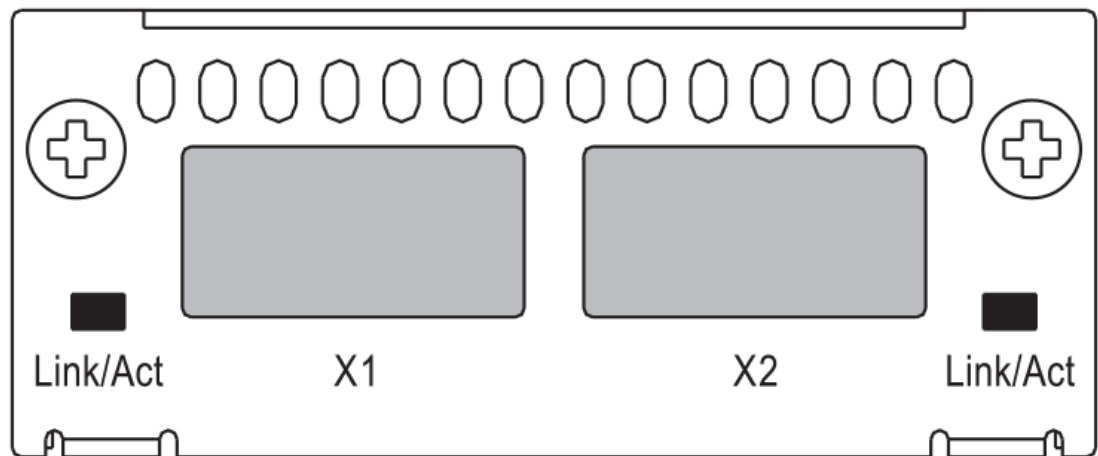
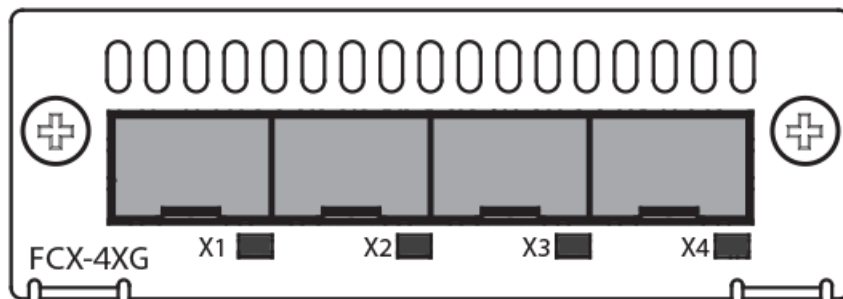

FIGURE 31 Four-port 10 Gbps SFP+ module on the front panel of FCX E/I devices



To connect FCX E/I devices and FCX S/S-F devices in a stack, you connect a 10 Gbps module on one device to a 10 Gbps module on another device. You cannot connect the 4-port 10 Gbps SFP+ module (FCX E/I) to the 16/10 Gbps CX4 stacking module (FCX S/S-F).

TABLE 17 Modules that connect FCX E/I and FCX S/S-F devices in a stack

This FCX E/I module connects to	These FCX S/S-F modules
4-port 10 Gbps SFP+ module	2-port 10 Gbps XFP module

NOTE

Trunking is not supported on the Brocade FCX Series.

Stacking configuration requirements

- Before configuring the stack using the CLI, physically connect the devices using stacking cables.
- To connect FCX S/S-F, and FCX E/I devices in a stack, you must reconfigure the default stacking ports on the FCX S/S-F devices to be the ports on the two-port 10 Gbps XFP module on the front panel using the **default-port** command.
- To use the ports in the 16/10 Gbps CX4 stacking module as data ports, you must reconfigure the stacking ports using the **longpreamble** command.
- To change the default stacking ports on the 4-port 10 Gbps SFP+ module from ports 1 and 2 to ports 3 and 4, you must reconfigure the default ports using the **default-port** command.

For information about configuring a stack, see the *FastIron Ethernet Switch Stacking Configuration Guide*.

Stacking cables

To connect Brocade FCX Series devices in a stack, you need to use specific cables.

TABLE 18 Cables used to connect Brocade FCX Series devices

To connect this FCX device	To this FCX device	Use this cable type
FCX S/S-F	FCX S/S-F	CX4 stacking cable
FCX E/I	FCX E/I	LC-LC MM fiber cables
FCX S/S-F	FCX E/I	LC-LC MM fiber cables

Stack size

A traditional stack can contain a combined maximum of eight FCX S, FCX S-F, FCS-E, and FCX-I devices.

Stacking topologies

Both linear and ring topologies are supported. In a linear stack topology there is a connection between each switch that carries two-way communications across the stack. This connection can use one port or two ports per trunk.

For example, in a four-unit stack using a linear topology, unit 1 connects to unit 2, unit 2 to unit 3, and unit 3 to unit 4.

In ring stack topology, there is an extra connection between the logical first and last devices forming a "ring" or "closed-loop." The closed-loop connection provides a redundant path for the stack link, so if one link fails, stack communications can be maintained.

For example, in a four-unit stack using a ring topology, unit 1 connects to unit 2, unit 2 to unit 3, unit 3 to unit 4, and unit 4 connects to unit 1.

FIGURE 32 FCX S devices in linear (top) and ring (bottom) stacking topologies

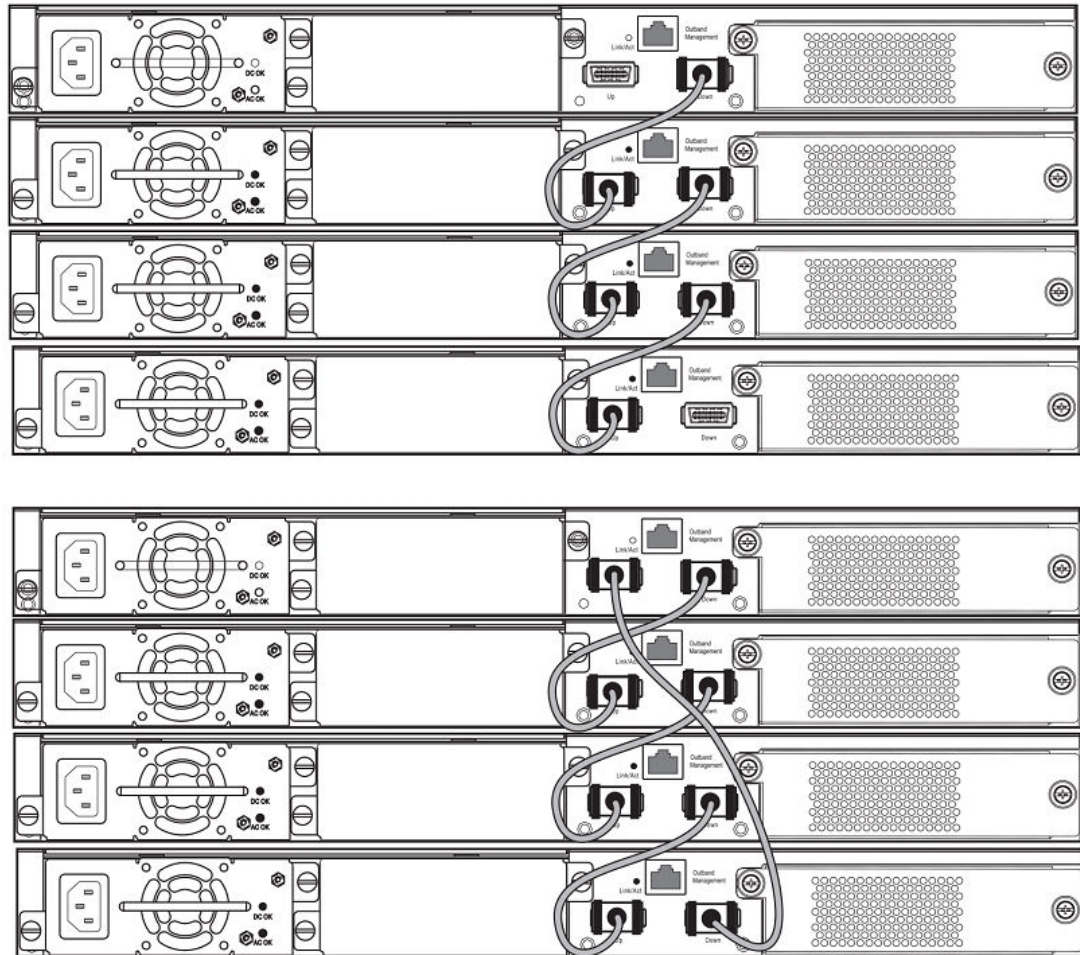

FIGURE 33 FCX E devices in a linear stacking topology

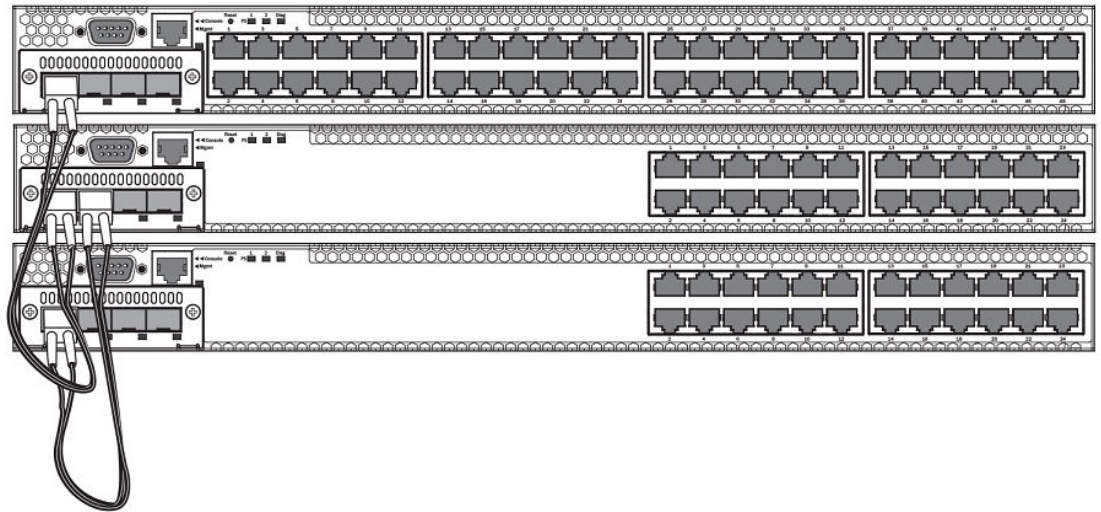

FIGURE 34 FCX E devices in a ring stacking topology

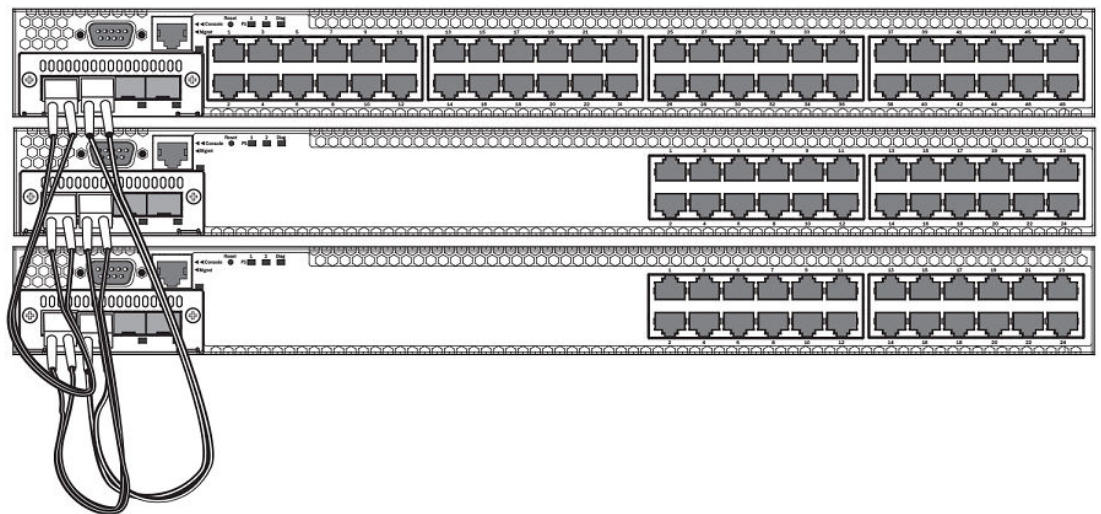
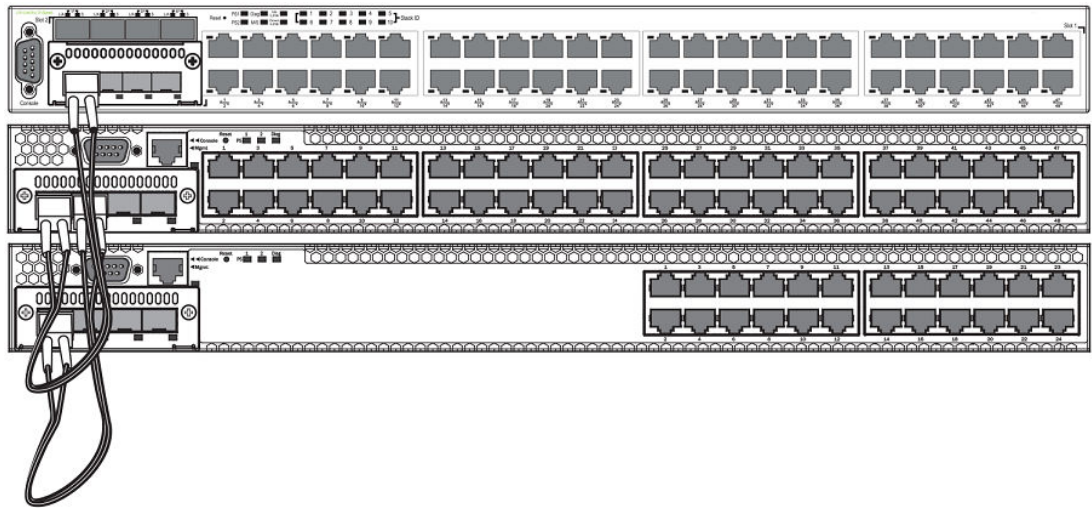

FIGURE 35 FCX S (top) and FCX E devices (bottom two devices) in a linear stacking topology



Extended distance stacking

Extended distance stacking allows stacking of devices in a distributed network environment. You can form a stack of co-located devices or devices located over an extended distance to form a distributed stack. Extended distance stacking provides resiliency, scalability, and ease of management whether the location of switches is in the same equipment rack or distributed across a network.

Currently we support stacking via CX4 up to 3M each, 10G Twinax fixed Copper up to 5M each and via Optical Stacking with the 10G-SR or 10G-MMF. The stacking range is SR:300M, MMF: 220M, and 10G-USR-SFP+: 100M. LR,ER,ZR,ZRD optics are not supported for stacking.

To set up extended distance stacking, use fiber optic cables to connect the devices in a stack. Contact your Brocade representative for information about supported fiber optic cables and distances.

Powering on the system

After you complete the physical installation, you can power on the system.

1. Remove the power cable from the shipping package.
2. Attach the AC power cable to the AC connector on the rear panel.
3. Insert the power cable plug into a 115V, 120V, or 240V outlet.

NOTE

To turn the system off, simply unplug the power cable or cables.

NOTE

The socket should be installed near the equipment and should be easily accessible.

NOTE

If the outlet is not rated 115/120V, stop and get the appropriate cable for the outlet.

Attaching a PC or terminal

To assign an IP address, you must have access to the Command Line Interface (CLI) . The CLI is a text-based interface that can be accessed through a direct serial connection to the device and through Telnet connections.

Access the CLI by attaching a serial cable to the Console port. After you assign an IP address, you can access the system through Telnet or Brocade Network Advisor.

Use the following steps to attach a management station to the serial port.

1. Connect a PC or terminal to the serial port of the system using a straight-through cable. The serial port has a male DB-9 connector.

NOTE

You need to run a terminal emulation program on the PC.

2. Launch the terminal emulation program and set the following session parameters:

- - Baud: 9600 bps
- Data bits: 8
- Parity: None
- Stop bits: 1
- Flow control: None

The EIA or TIA 232 serial communication port serves as a connection point for management by a PC or SNMP workstation. Brocade devices come with a standard male DB-9 connector.

FIGURE 36 Serial Port (DB-9 DTE) Pin-Out

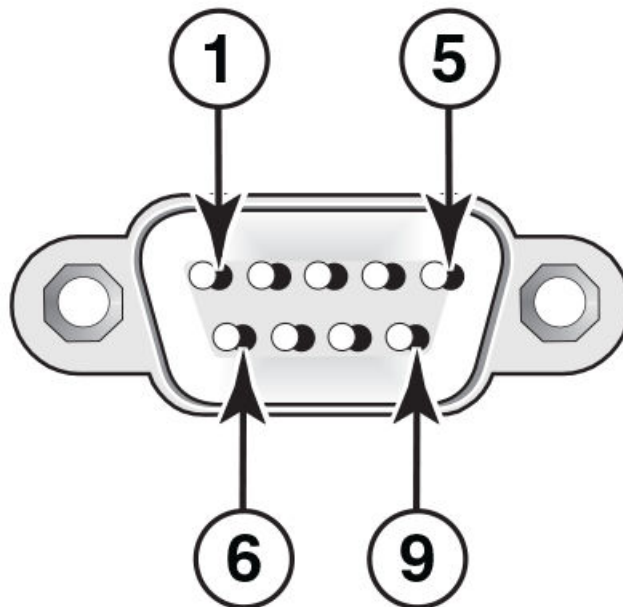

Most PC serial ports also require a cable with a female DB-9 connector. Terminal connections will vary, requiring either a DB-9 or DB-25 connector, male or female. For more information about serial cable options between a Brocade device and a PC or terminal, see [Wiring map for serial cable](#) on page 50.

Wiring map for serial cable

TABLE 19 Serial cable wiring

Switch 9-Pin Serial Port	Null Modem	PC 9-Pin DTE Port
2 TXD (transmit data)	----->	2 RXD (receive data)
3 RXD (receive data)	<-----	3 TXD (transmit data)
5 SGND (signal ground)	<----->	5 SGND (signal ground)
No other pins are used.		

NOTE

As indicated in the table above, some of the wires should not be connected.

Installing and replacing a power supply unit



CAUTION

For FCX624-E, FCX624-I, FCX648-E, and FCX648-I devices, be sure that the airflow direction of the power supply unit matches that of the installed fan tray. The power supplies and fan trays are clearly labeled with either a green arrow with an "E", or an orange arrow with an "I".

FIGURE 37 Installing a power supply unit

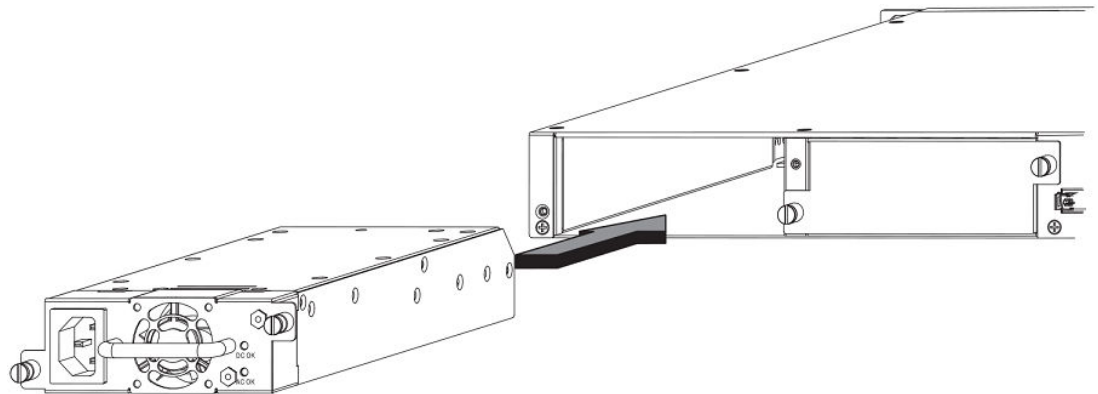

Use the following steps to install a power supply unit in the switch.

1. Remove the blank metal plate (or a previously installed PSU) from the appropriate slot by removing the two screws with a flat-head screwdriver.
2. Before opening the package that contains the PSU, touch the bag to the switch casing to discharge any potential static electricity. Brocade recommends using an ESD wrist strap during installation.
3. Remove the PSU from the anti-static shielded bag.

4. Holding the PSU level, guide it into the carrier rails on each side and gently push it all the way into the slot, ensuring that it firmly engages with the connector.
5. When you are sure the PSU has properly engaged the connector, tighten the retainer screws to secure the in PSU the slot.

When the device is powered on, the PSU AC and DC LEDs on the PSU back panel should turn green to confirm that the PSU is correctly installed and supplying power.



CAUTION

If you do not install a PSU in a slot, you must keep the slot panel in place. If you run the device with an uncovered slot, the system will overheat.

Installing or replacing fan trays



CAUTION

For FCX624-E, FCX624-I, FCX648-E, and FCX648-I devices, be sure that the airflow direction of the power supply unit matches that of the installed fan tray. The power supplies and fan trays are clearly labeled with either a green arrow with an "E", or an orange arrow with an "I". On these devices, the fan trays are hot-swappable.

FIGURE 38 Installing a fan tray on FCX624-E, FCX624-I, FCX648-E, and FCX648-I devices

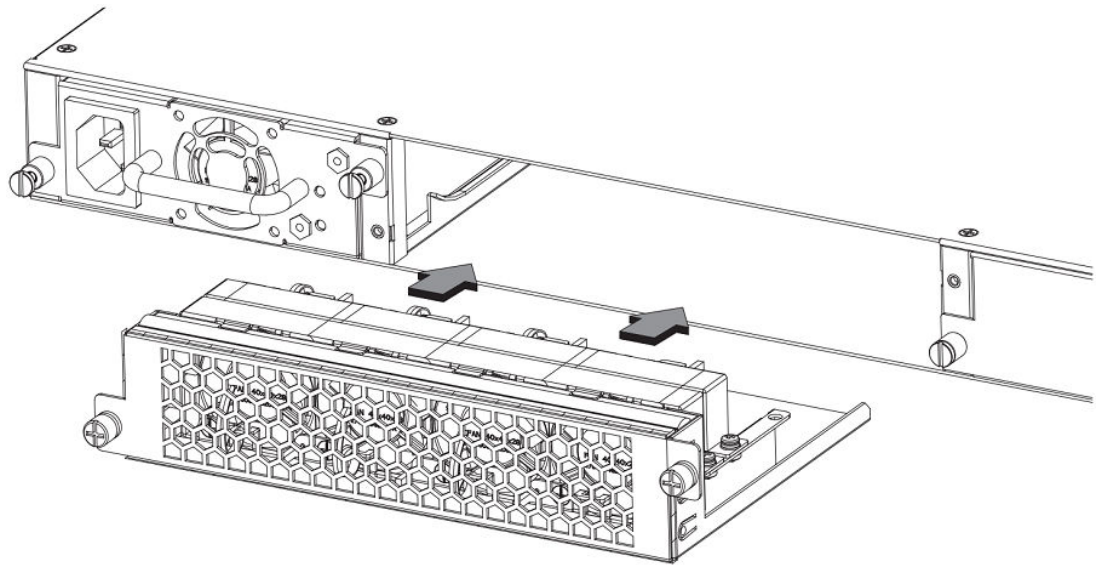
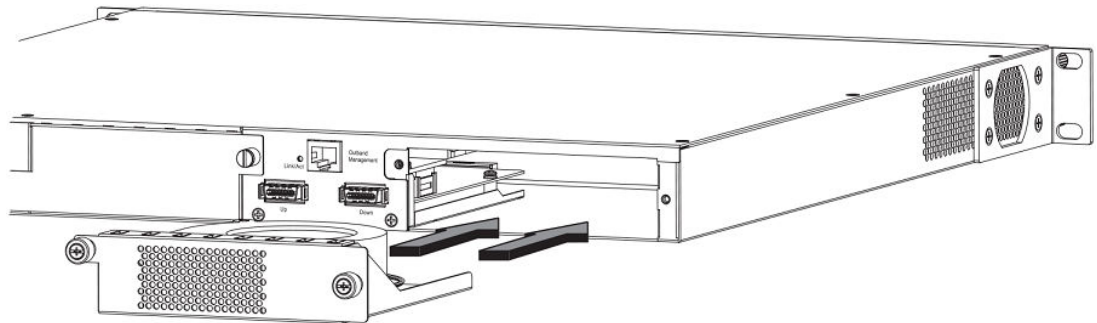

FIGURE 39 Installing a fan tray on Brocade FCX 624S, FCX 648S, FCX 624S-F, FCX 624S-HPOE, and FCX 648S-HPOE devices



Perform the following steps to install a fan tray in the switch.

1. Remove the installed fan tray from the slot by removing the two screws with a crosshead or Philips screwdriver.
2. Before opening the package that contains the new fan tray, touch the bag to the switch casing to discharge any potential static electricity. It is recommended that you wear an ESD wrist strap during installation.

3. Remove the fan tray from the anti-static shielded bag.
4. Holding the fan tray level, guide it into the carrier rails on each side and gently push it all the way into the slot, ensuring that it firmly engages with the connector.
5. When you are sure the fan tray has properly engaged the connector, tighten the retainer screws to secure the fan tray in the slot.

NOTE

The fans are controlled by software, and their speed is set according to the environmental temperature surrounding the switch.

Installing an optional module

FIGURE 40 Installing an optional module on Brocade FCX 624S, FCX 648S, FCX 624S-F, FCX 624S-HPOE, and FCX 648S-HPOE devices

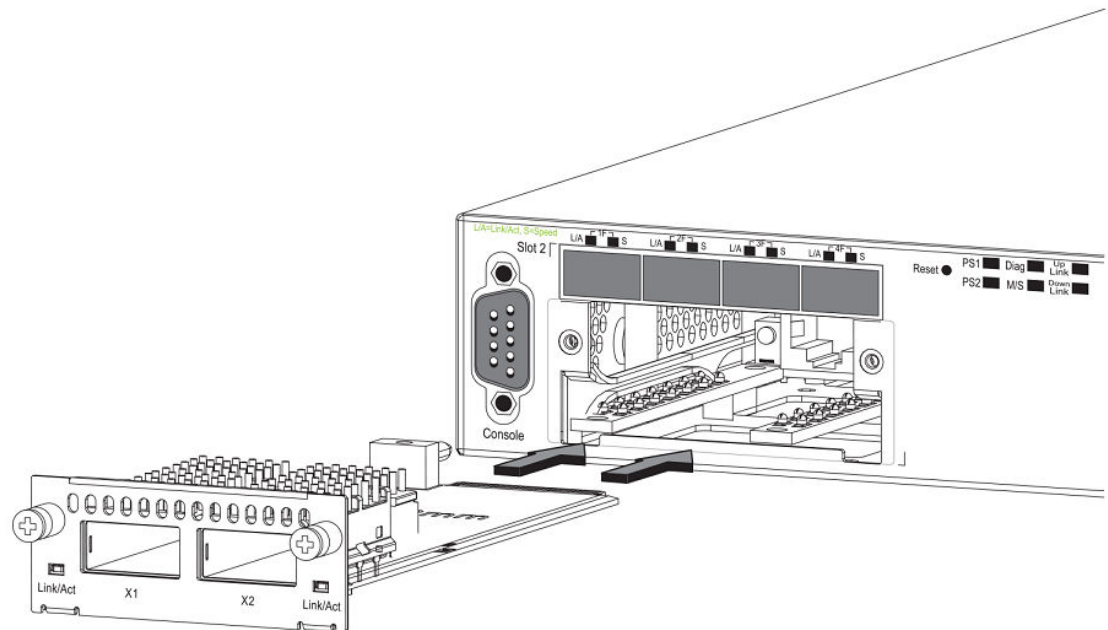

Brocade FCX 624S, FCX 648S, FCX 624S-F, FCX 624S-HPOE, and FCX 648S-HPOE switches support an optional two-port 10 Gbps Ethernet XFP module. Brocade recommends that the system is powered down for installation as the 2x10 XFP module is not hot swappable.

FIGURE 41 Installing an optional module in FCX624-E, FCX624-I, FCX648-E, and FCX648-I devices

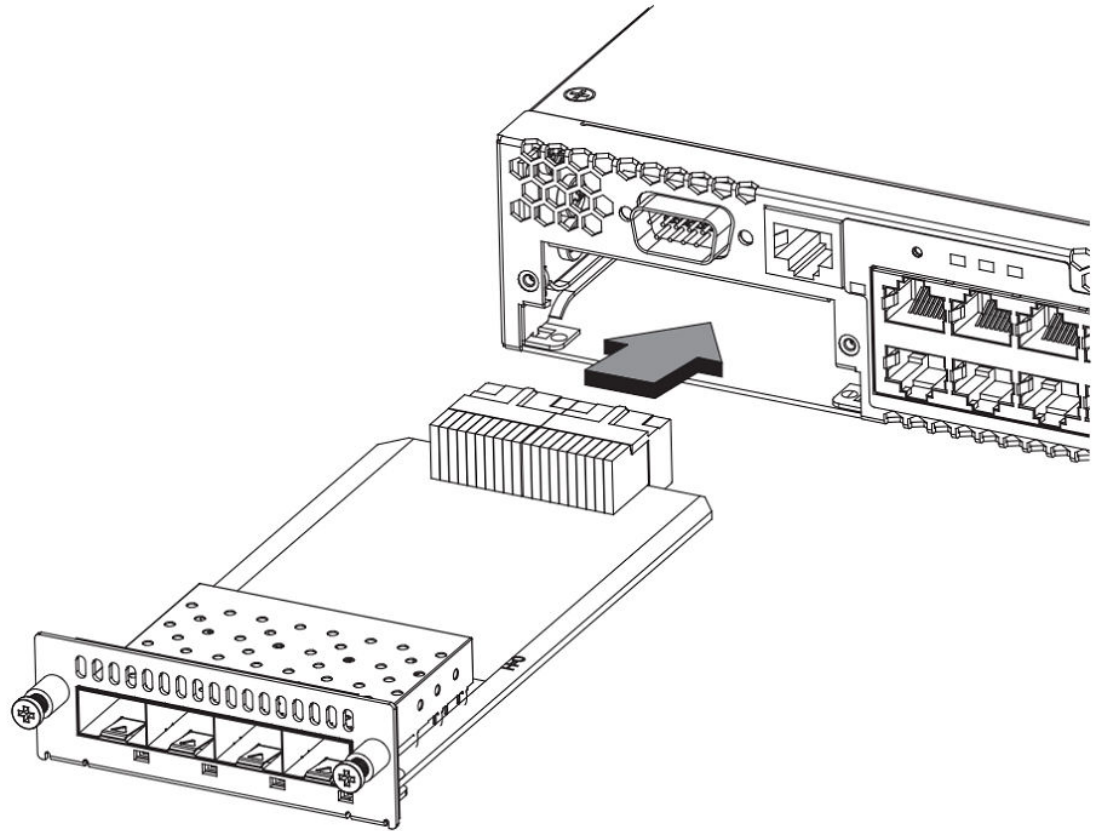

FCX624-E, FCX624-I, FCX648-E, and FCX648-I switches support an optional four-port 1 Gbps SFP module or four-port 10 Gbps SFP+ module. The 10 Gbps SFP+ module allows you to use your device in a stack.



CAUTION

On FCX624-E, FCX624-I, FCX648-E, and FCX648-I switches, optional SFP and SFP+ modules are not hot-swappable. Be sure to power-down your device before you install or replace a module.

Perform these steps to install an optional module.

1. Remove the blank metal plate (or an installed module) from the slot by removing the two screws with a Phillips screwdriver.
2. Before opening the package that contains the module, touch the bag to the switch casing to discharge any potential static electricity. It is recommended that you wear an ESD wrist strap during installation.
3. Remove the module from the anti-static shielded bag.
4. Holding the module level, guide it into the carrier rails on each side and gently push it all the way into the slot, ensuring that it firmly engages with the connector.

5. When you are sure the module has properly engaged the connector, tighten the retainer screws to secure the module in the slot.
6. When the switch is powered on, the LEDs will function as described in [Port, system, and power status LEDs for Brocade FCX 624S, FCX 648S, FCX 624S-F, FCX 624S-HPOE, and FCX 648S-HPOE](#) on page 25.

**CAUTION**

If you do not install a module in a slot, you must keep the slot panel in place. If you run the device with an uncovered slot, the system will overheat.

Optional 2-port 10 Gbps SFP+ uplink module

Feature description for the 2-port 10 Gbps SFP+ module including modified CLI examples

The following Brocade FCX devices include a slot on the front panel for a two-port 10 Gbps SFP+ uplink module. This module operates at 10 Gbps full duplex.

- Brocade FCX 624S
- Brocade FCX 648S
- Brocade FCX 624S-F
- Brocade FCX 624S-HPOE
- Brocade FCX 648S-HPOE

The 2-port 10 Gbps SFP+ uplink module can replace the 2-port XFP module in the fixed slot 3. Port mapping is the same as for the 2x10 XFP with slot 3 and port 1 or 2, for example, 1/3/1 and 1/3/2. Stacking is supported using the **stack default-port** command with the 1/3/1 and 1/3/2 options.

The module is named FCX-2SFPP 2-port 10G Module (2-SFP+) in configuration and output.

NOTE

Reload the device whenever you install or replace the module because the 2x10 SFP+ module is not hot swappable.



CAUTION

Power-down your device before you install or replace a module for safety purposes and to avoid instability due to a delay in power cycling.

FIGURE 42 Two-port 10 Gbps SFP+ module

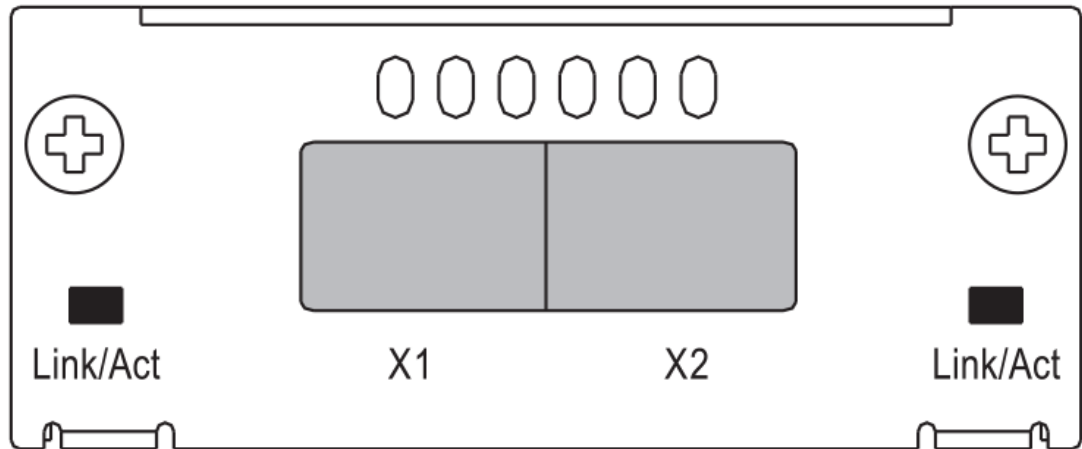

TABLE 20 10 Gbps SFP+ module port status LEDs

LED	Condition	Status
Link or Act LED (Link or Activity)	On or flashing green	Port has a valid link at 10 Gbps. Flashing indicates activity.
	Off	The port is down.

Modified CLI examples for the 2-port 10 Gbps SFP+ module

The following sample output from the **show module** command displays an entry for the 2-port 10G SFP+ module.

```
device# show module
Module
U1:M1 FCX-48GS POE 48-port Management Module      Status Ports Starting MAC
U1:M2 FCX-2XGC 2-port 16G Module (2-CX4)          OK      48      0024.38c9.4d00
U1:M3 FCX-2SFPP 2-port 10G Module (2-SFP+)        OK      2       0024.38c9.4d31
U1:M3 FCX-2SFPP 2-port 10G Module (2-SFP+)        OK      2       0024.38c9.4d33
```

The following sample output from the **show version** command shows that the 2-port 10G SFP+ module is in slot 3.

```
device# show version
Copyright (c) 1996-2011 Brocade Communications Systems, Inc.
UNIT 1: compiled on Oct 18 2012 at 16:01:04 labeled as FCXS07300b1
(5373912 bytes) from Primary FCXS07300b1.bin
SW: Version 07.3.00b1T7f1
Boot-Monitor Image size = 370663, Version:07.3.00T7f5 (grz07300b1)
HW: Stackable FCX648S-HPOE-PREM (PROM-TYPE FCX-ADV-U)
=====
UNIT 1: SL 1: FCX-48GS POE 48-port Management Module
Serial #: BCYXXXXXXXXX
License: BASE_SOFT_PACKAGE (LID: deaHHJIhFNb)
P-ENGINE 0: type DB90, rev 01
P-ENGINE 1: type DB90, rev 01
PROM-TYPE: FCX-ADV-U
=====
UNIT 1: SL 2: FCX-2XGC 2-port 16G Module (2-CX4)
=====
UNIT 1: SL 3: FCX-2SFPP 2-port 10G Module (2-SFP+)
=====
800 MHz Power PC processor 8544E (version 0021/0022) 400 MHz bus
65536 KB flash memory
256 MB DRAM
STACKID 1 system uptime is 2 days 10 minutes 24 seconds
The system : started=warm start reloaded=by "reload"
```

The following is sample output of the **show running-config** command.

```
device# show running-config
!
Startup-config data location is flash memory
!
Startup configuration:
!
ver 07.3.00a001T7f1
!
stack unit 1
  module 1 fcx-48-poe-port-management-module
  module 2 fcx-cx4-2-port-16g-module
  module 3 fcx-sfpp-2-port-10g-module
!
```

The following is sample output of the **show media** and **show optic** commands with some configuration.

```
device# show media
1/1/1:C 1/1/2:C 1/1/3:C 1/1/4:C 1/1/5:C 1/1/6:C 1/1/7:C 1/1/8:C
1/1/9:C 1/1/10:C 1/1/11:C 1/1/12:C 1/1/13:C 1/1/14:C 1/1/15:C 1/1/16:C
1/1/17:C 1/1/18:C 1/1/19:C 1/1/20:C 1/1/21:C 1/1/22:C 1/1/23:C 1/1/24:C
1/1/25:C 1/1/26:C 1/1/27:C 1/1/28:C 1/1/29:C 1/1/30:C 1/1/31:C 1/1/32:C
1/1/33:C 1/1/34:C 1/1/35:C 1/1/36:C 1/1/37:C 1/1/38:C 1/1/39:C 1/1/40:C
1/1/41:C 1/1/42:C 1/1/43:C 1/1/44:C 1/1/45:C 1/1/46:C 1/1/47:C 1/1/48:C
1/2/1:XG-CX4 1/2/2:XG-CX4
1/3/1:XG-SR 1/3/2:XG-SR
device# show media e 1/3/1
Port 1/3/1: Type : 10G XG-SR(SFP +)
Vendor: Brocade Version: 1
Part# : PLRXPLSCS4371 Serial#: CXXXXXXXXX
device(config)# op 1
Enable optical monitoring and set alarm/warn interval to 1 minute(s)
```

Installing the FCX Switch

```
device(config)# show optic 1/3/1
  Port  Temperature  Tx Power  Rx Power  Tx Bias Current
+-----+-----+-----+-----+-----+
1/3/1   32.7421 C  -002.3195 dBm -002.5947 dBm  6.212 mA
        Normal      Normal      Normal      Normal
device# show media e 1/3/1
Port 1/3/1: Type : 10G XG-ER(SFP +)
        Vendor: BROCADE      Version: A
        Part# : 57-0000085-01  Serial#: XXXXXXXXXXXXXXXX
device# show media e 1/3/2
Port 1/3/2: Type : 10G XG-USR (SFP +)
        Vendor: BROCADE      Version: A
        Part# : 57-1000130-01  Serial#: XXXXXXXXXXXXXXXX
device# show media
1/1/1:C 1/1/2:C 1/1/3:C 1/1/4:C 1/1/5:C 1/1/6:C 1/1/7:C 1/1/8:C
1/1/9:C 1/1/10:C 1/1/11:C 1/1/12:C 1/1/13:C 1/1/14:C 1/1/15:C 1/1/16:C
1/1/17:C 1/1/18:C 1/1/19:C 1/1/20:C 1/1/21:C 1/1/22:C 1/1/23:C 1/1/24:C
1/1/25:C 1/1/26:C 1/1/27:C 1/1/28:C 1/1/29:C 1/1/30:C 1/1/31:C 1/1/32:C
1/1/33:C 1/1/34:C 1/1/35:C 1/1/36:C 1/1/37:C 1/1/38:C 1/1/39:C 1/1/40:C
1/1/41:C 1/1/42:C 1/1/43:C 1/1/44:C 1/1/45:C 1/1/46:C 1/1/47:C 1/1/48:C
1/2/1:XG-CX4 1/2/2:XG-CX4
1/3/1:XG-ER 1/3/2:XG-USR
```

Checking Network Devices and Testing Connectivity

- [Assigning permanent passwords..... 59](#)
- [Configuring IP addresses..... 61](#)
- [Testing connectivity..... 71](#)
- [Troubleshooting network connections..... 74](#)



CAUTION

The procedures in this manual are for qualified service personnel.

Assigning permanent passwords

By default, the CLI is not protected by passwords. To secure CLI access, Brocade strongly recommends assigning passwords. See the *FastIron Ethernet Switch Administration Guide*.

NOTE

You can assign passwords using Brocade Network Advisor if an enable password for a Super User has been configured on the device.

The CLI contains the following access levels:

- **User EXEC** - The level you enter when you first start a CLI session. At this level, you can view some system information but you cannot configure system or port parameters.
- **Privileged EXEC** - This level is also called the Enable level and can be secured by a password. You can perform tasks such as manage files on the flash module, save the system configuration to flash, and clear caches at this level.
- **CONFIG** - The configuration level. This level lets you configure the system IP address and configure switching and routing features. To access the CONFIG mode, you must already be logged into the Privileged level of the EXEC mode.

You can set the following levels of Enable passwords:

- **Super User** - Allows complete read-and-write access to the system. This is generally for system administrators and is the only password level that allows you to configure passwords.

NOTE

You must set a super user password before you can set other types of passwords.

- **Port Configuration** - Allows read-and-write access for specific ports but not for global (system-wide) parameters.
- **Read Only** - Allows access to the Privileged EXEC mode and CONFIG mode but only with read access.

Setting passwords

1. At the opening CLI prompt, enter the following command to change to the Privileged level of the EXEC mode:

```
device> enable
```

2. Access the CONFIG level of the CLI by entering the following command:

```
device# configure terminal
device(config)#
```

3. Enter the following command to set the super user password:

```
device(config)# enable super-user-password
text
```

NOTE

You must set the super user password before you can set other types of passwords.

4. Enter the following commands to set the port configuration and read-only passwords:

```
device(config)# enable port-config-password
text
device(config)# enable read-only-password
text
```

NOTE

If you forget your super user password, refer to [Recovering from a lost password](#) on page 60.

Syntax: `enable super-user-password | read-only-password | port-config-password text`

Passwords can be up to 32 characters long.

Recovering from a lost password

By default, the CLI does not require passwords. However, if someone has configured a password for the device but the password has been lost, you can regain super user access to the device using the following procedure.

NOTE

Recovery from a lost password requires direct access to the serial port and a system reset.

Use the following procedure to recover from a lost password.

1. Start a CLI session over the serial interface to the Brocade device.
2. Reboot the device.
3. While the system is booting, before the initial system prompt appears, enter **b** to enter the boot monitor mode.
4. Enter **no password** at the prompt. (You cannot abbreviate this command.)
5. Enter **boot system flash primary** at the prompt. This command causes the device to bypass the system password check.

After the console prompt reappears, assign a new password.

Configuring IP addresses

You must configure at least one IP address using the serial connection to the CLI before you can manage the system using the other management interfaces.

Brocade devices support both classical IP network masks (Class A, B, and C subnet masks, and so on) and Classless Interdomain Routing (CIDR) network prefix masks.

- To enter a classical network mask, enter the mask in IP address format. For example, enter "10.157.22.99 255.255.255.0" for an IP address with a Class-C subnet mask.
- To enter a prefix number for a network mask, enter a forward slash (/) and the number of bits in the mask immediately after the IP address. For example, enter "209.157.22.99/24" for an IP address that has a network mask with 24 significant ("mask") bits.

By default, the CLI displays network masks in classical IP address format (example: 255.255.255.0). You can change the display to the prefix format. See the *FastIron Ethernet Switch Administration Guide*.

Devices running Layer 2 software

Use the following procedure to configure an IP Address on a device running Layer 2 software.

1. At the opening CLI prompt, enter **enable** .

```
device> enable
```

2. Enter the following command at the Privileged EXEC level prompt (for example, Brocade#), then press **Enter** . This command erases the factory test configuration if still present:

```
device# erase startup-config
```



CAUTION

Use the erase startup-config command only for new systems. If you enter this command on a system you have already configured, the command erases the configuration. If you accidentally do erase the configuration on a configured system, enter the write memory command to save the running configuration to the startup-config file.

3. Access the configuration level of the CLI by entering the following command:

```
device# configure terminal
(Privileged EXEC Level)
device(config)# (Global CONFIG Level)
```

4. Configure the IP address and mask for the switch.

```
device(config)# ip address 10.22.3.44 255.255.255.0
```

5. Set a default gateway address for the switch.

```
device(config)# ip default-gateway 10.22.3.1
```

NOTE

You do not need to assign a default gateway address for single subnet networks.

Syntax: `enable [password]`

Syntax: `configure terminal`

Syntax: `[no] ip address ip-addr ip-mask`

or

Syntax: [no] ip address *ip-addr/mask-bits*

Syntax: ip default-gateway *ip-addr*

Devices running Layer 3 software

Before attaching equipment to a Brocade Layer 3 Switch, you must assign an interface IP address to the subnet on which the router will be located. You must use the serial connection to assign the first IP address. For subsequent addresses, you also can use the CLI through Telnet.

By default, you can configure up to 24 IP interfaces on each port, virtual interface, and loopback interface. You can increase this amount to up to 64 IP subnet addresses per port by increasing the size of the subnet-per-interface table.

The following procedure shows how to add an IP address and mask to a router port.

1. At the opening CLI prompt, enter **enable** .

```
device> enable
```

2. Enter the following command at the CLI Privileged EXEC level prompt, then press Enter. This command erases the factory test configuration if still present:

```
device# erase startup-config
```



CAUTION

Use the erase startup-config command only for new systems. If you enter this command on a system you have already configured, the command erases the configuration. If you accidentally do erase the configuration on a configured system, enter the write memory command to save the running configuration to the startup-config file.

3. Access the configuration level of the CLI by entering the following command:

```
device# configure terminal
(Privileged EXEC Level)
device(config)# (Global CONFIG Level)
```

4. Configure the IP addresses and mask addresses for the interfaces on the router.

```
device(config)# int e 1/1/2
device(config-if-e1000-1/1/2)# ip address 10.22.3.44
255.255.255.0
```

NOTE

You can use the syntax **ip address ip-addr /mask-bits** if you know the subnet mask length. In the above example, you could enter **ip address 10.22.3.44 /24** .

Syntax: enable [*password*]

Syntax: configure terminal

Syntax: [no] ip address *ip-addr ip-mask* [**secondary**]

or

Syntax: [no] ip address *ip-addr/mask-bits* [**secondary**]

Use the **secondary** parameter if you have already configured an IP address within the same subnet on the interface.

Configuring IP parameters for devices running Layer 3 software

This section describes how to configure IP parameters for devices running Layer 3 software.

Configuring IP addresses

You can configure an IP address on the following types of Layer 3 switch interfaces:

- Ethernet port
- Virtual routing interface (also called a Virtual Ethernet or "VE")
- Loopback interface

By default, you can have up to 24 IP addresses on each interface, but you can increase this number to 128 IP addresses.

NOTE

Once you configure a virtual routing interface on a VLAN, you cannot configure Layer 3 interface parameters on individual ports in the VLAN. Instead, you must configure the parameters on the virtual routing interface itself.

Brocade devices support both classical IP network masks (Class A, B, and C subnet masks, and so on) and Classless Interdomain Routing (CIDR) network prefix masks.

- To enter a classical network mask, enter the mask in IP address format. For example, enter "10.157.22.99 255.255.255.0" for an IP address with a Class-C subnet mask.
- To enter a prefix network mask, enter a forward slash (/) and the number of bits in the mask immediately after the IP address. For example, enter "10.157.22.99/24" for an IP address that has a network mask with 24 significant bits (ones).

By default, the CLI displays network masks in classical IP address format (for example: 255.255.255.0). You can change the display to prefix format.

Assigning an IP address to an Ethernet port

Enter the following commands to assign an IP address to port 1/1/1.

```
device(config)# interface ethernet 1/1/1
device(confi-if-1/1/1)#FLS Router ip address 10.45.6.1 255.255.255.0
```

NOTE

You also can enter the IP address and mask in CIDR format, as follows:

```
device(confi-if-1/1/1)# ip address 10.45.6.1/24
```

Syntax: [no] ip address *ip-addr ip-mask*

or

Syntax: [no] ip address *ip-addr/mask-bits*

Assigning an IP address to a loopback interface

Loopback interfaces are always up, regardless of the states of physical interfaces. They can add stability to the network because they are not subject to route flap problems that can occur due to unstable links between a Layer 3 Switch and other devices. You can configure up to four loopback interfaces on a Layer 3 switch.

You can add up to 24 IP addresses to each loopback interface.

NOTE

If you configure the Brocade switch to use a loopback interface to communicate with a BGP4 neighbor, you must also configure a loopback interface on the neighbor and configure the neighbor to use that loopback interface to communicate with the Brocade switch.

To add a loopback interface, enter commands such as those shown in the following example:

```
device(config)# exit
device(config)# int loopback 1
device(config)# ip address 10.0.0.1/24
```

Syntax: interface loopback *num*

The *num* parameter specifies the virtual interface number. You can specify from 1 to the maximum number of virtual interfaces supported on the device. To display the maximum number of virtual interfaces supported on the device, enter the **show default values** command. The maximum is listed in the System Parameters section, in the Current column of the virtual-interface row.

Assigning an IP address to a virtual routing interface

A virtual interface is a logical port associated with a Layer 3 Virtual LAN (VLAN) configured on a Layer 3 switch. You can configure routing parameters on the virtual interface to enable the Layer 3 switch to route protocol traffic from one Layer 3 VLAN to the other, without using an external router.

This section describes how to configure an IP address on a virtual interface.

NOTE

The switch uses the lowest MAC address on the device (the MAC address of port 1 or 1/1/1) as the MAC address for all ports within all virtual interfaces you configure on the device.

Enter commands similar to the following to add a virtual interface to a VLAN and configure an IP address on the interface.

```
device(config)# vlan 2 name IP-Subnet_10.1.2.1/24
device(config)# untag 1/1/1 to 1/1/4
device(config)# router-interface ve1
device(config)# interface ve1
device(config)# ip address 10.1.2.1/24
```

The first two commands in this example create a Layer 3 protocol-based VLAN name "*IP-Subnet_10.1.2.1/24*" and add a range of untagged ports to the VLAN. The **router-interface** command creates virtual interface 1 as the routing interface for the VLAN. The last two commands change to the interface configuration level for the virtual interface and assign an IP address to the interface.

Syntax: router-interface ve *num*

Syntax: interface ve *num*

Deleting an IP address

Enter a command similar to the following to delete an IP address.

```
device(config-if-1/1/1)# no ip address 10.1.2.1
```

This command deletes IP address 10.1.2.1. You do not need to enter the subnet mask.

To delete all IP addresses from an interface, enter the following command:

```
device(config-if-1/1/1)# no ip address *
```

Syntax: [no] ip address *ip-addr* | *

Connecting network devices

Brocade devices support connections to other vendors' routers, switches, and hubs, as well other Brocade devices.

Connectors

For port pinouts, refer to [Pinouts and signalling](#) on page 89.

Cable specifications



CAUTION

Before plugging a cable to any port, be sure to discharge the voltage stored on the cable by touching the electrical contacts to ground surface.

Refer to "Cable specifications" for cable lengths and types.

Connecting to Ethernet or fast Ethernet hubs

For copper connections to Ethernet hubs, a 10/100BaseTX or 1000BaseT switch, or another Brocade device, a crossover cable is required. If the hub is equipped with an uplink port, it will require a straight-through cable instead of a crossover cable.

NOTE

The 802.3ab standard (automatic MDI or MDIX detection) calls for automatic negotiation of the connection between two 1000Base-T ports. In this case a straight-through cable may work just as well

as a crossover cable. For more information about this feature, see the *FastIron Ethernet Switch Security Configuration Guide*.

FIGURE 43 UTP crossover cable

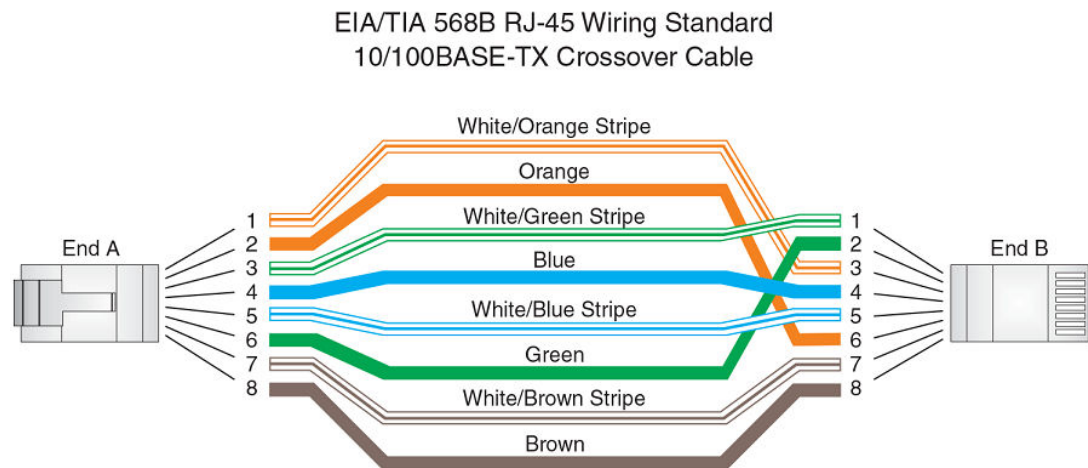
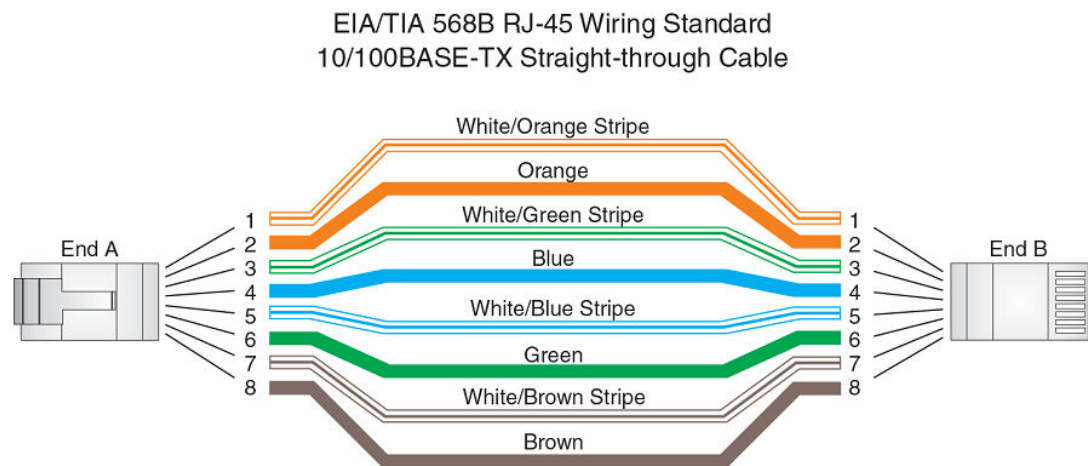

FIGURE 44 Straight-through cable



Connecting to workstations, servers, or routers

Straight-through UTP cabling is required for direct UTP attachment to workstations, servers, or routers using network interface cards (NICs).

Fiber cabling is required for direct attachment to Gigabit NICs or switches and routers through fiber ports. Refer to [Connecting a network device to a fiber port](#) on page 67.

Automatic MDI or MDIX detection

All 10/100 and Gbps Ethernet Copper ports on the devices support automatic Media Dependent Interface (MDI) and Media Dependent Interface Crossover (MDIX) detection. This feature is enabled on all 10/100 and Gigabit copper ports by default. For each port, you can disable auto MDI or MDIX, designate the port as an MDI port, or designate the port as an MDIX port.

For more information about this feature and how configure it, refer to *FastIron Ethernet Switch Security Configuration Guide*.

Connecting a network device to a fiber port

For direct attachment from the device to a Gbps NIC, switch, or router, using a fiber optic transceiver, you will need fiber cabling with an LC connector.

To connect the device to another network device using a fiber port, you must do the following tasks:

- Install a fiber optic transceiver (XFP, SFP, or SFP+)
- Cable the fiber optic transceiver

The following sections describe these tasks.

Fiber Optic transceivers

The following table lists supported XFP transceivers (for stacking and non-stacking FCX models) and supported SFP and SFP+ transceivers.

TABLE 21 Supported XFP transceivers for Brocade FCX 624S, FCX 648S, FCX 624S-F, FCX 624S-HPOE, and FCX 648S-HPOE devices

10 Gigabit Optic	Distance	Supported for stacking
10GBase-SR	300m	Yes
10GBase-LR	10km	No
10GBase-ER	40km	No
10GBase-LRM (1310-MMF)	200m	No
10G-ZR	80km	No
10GBase-ZRD	80km	No

TABLE 22 Supported SFP transceivers for FCX624-E, FCX624-I, FCX648-E, and FCX648-I devices

10 Gigabit Optic	Distance	Supported for stacking
10GSFP-SR	300m	Yes
10GSFP-LR	10km	No

Installing a transceiver

You can install a new transceiver in an XFP, SFP, or SFP+ slot while the device is powered on and running.

While installing a transceiver, wear an ESD wrist strap with a plug for connection to a metal surface.

NOTE

For safety reasons, the ESD wrist strap should contain a series 1 meg ohm resistor.



CAUTION

All fiber optic interfaces use Class 1 lasers.

Use the following steps to install a transceiver.

1. Put on the ESD wrist strap and ground yourself by attaching the clip end to a metal surface (such as an equipment rack) to act as ground.
2. Remove the new transceiver from the protective packaging.
3. Gently insert the transceiver into the slot until it clicks into place. Transceivers are keyed to prevent incorrect insertion.

FIGURE 45 Installing a transceiver into FCX-624S, FCX-648S, FCX-624S, FCX-624S-HPOE, and FCX-648S-HPOE devices

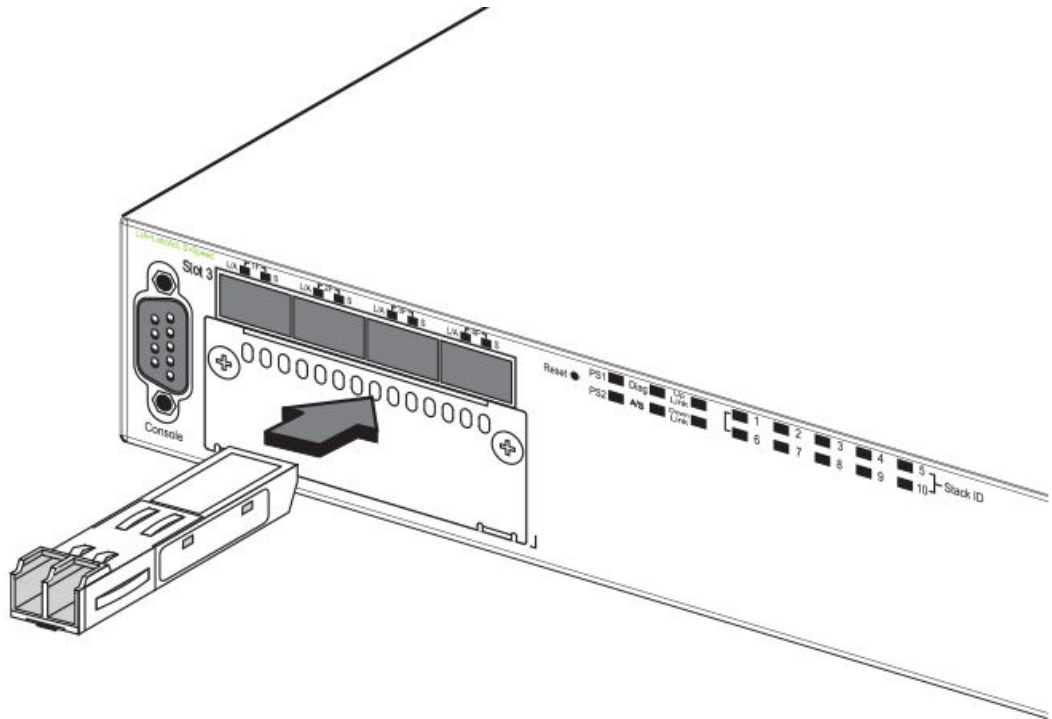
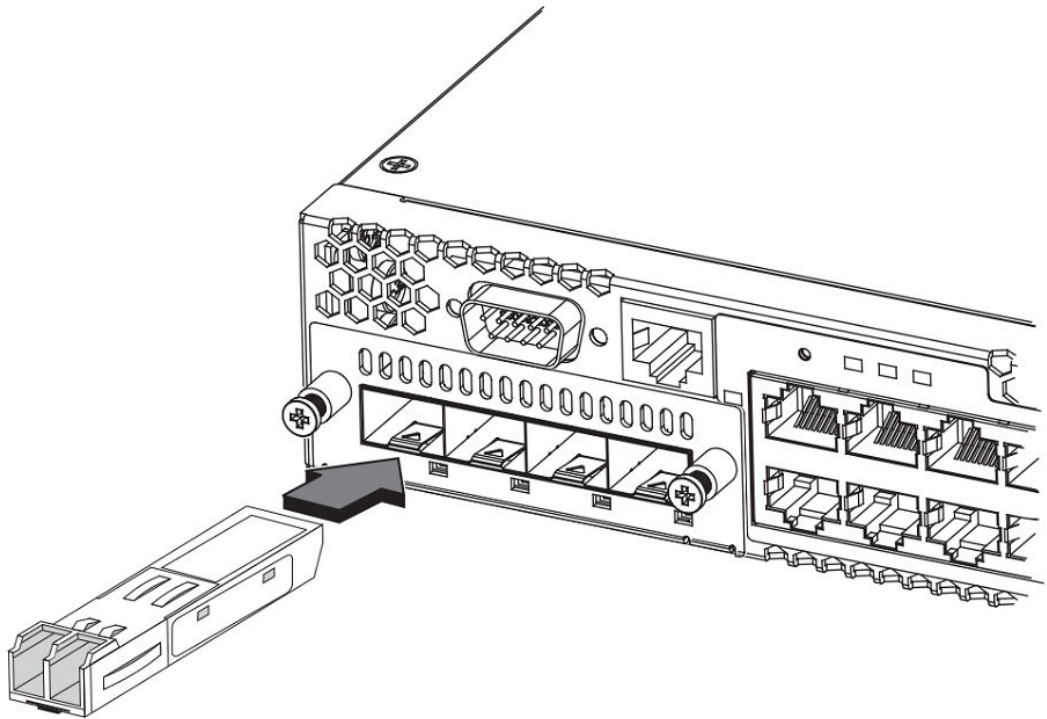

FIGURE 46 Installing a transceiver into Brocade FCX 624-E, FCX 624-I, FCX 648-E, and FCX 648-I devices



Cabling a fiber optic transceiver

Use the following steps to cable a fiber optic transceiver.

1. Remove the protective covering from the fiber-optic port connectors and store the covering for future use.
2. Before cabling a fiber optic transceiver, Brocade strongly recommends cleaning the cable connectors and the port connectors. For more information, refer to [Cleaning the fiber optic connectors](#) on page 70.
3. Gently insert the cable connector (a tab on each connector should face upward) into the transceiver connector until the tabs lock into place.
4. Observe the link and active LEDs to determine if the network connections are functioning properly. For more information about the LED indicators, refer to [Observing LEDs](#) on page 71.

Cleaning the fiber optic connectors

To avoid problems with the connection between the fiber optic transceiver (SFP, SFP+, or mini-GBIC) and the fiber cable connectors, Brocade strongly recommends cleaning both connectors each time you disconnect and reconnect them. Dust can accumulate in the connectors and cause problems such as reducing the optic launch power.

To clean the fiber cable connectors, Brocade recommends using a fiber optic reel-type cleaner. You can purchase this type of cleaner from the following Website:

http://www.fisfiber.com/Home_Page.asp

When not using an SFP connector, make sure to keep the protective covering in place.

Testing connectivity

Test for connectivity by observing the LEDs related to network connection.

Pinging an IP address

To verify that a FastIron CX device can reach another device through the network, enter a command similar to the following at any level of the CLI.

```
device> ping 10.33.4.7
```

Syntax: ping *ip-addr* [**source** *ip-addr*] [**countnum**] [**timeout msec**] [**tll num**] [**verify**] [**no-fragment**] [**quiet**] [**data 1-to-4-byte-hex#**] [**numeric**] [**size byte**] [**brief [max-print-per-sec num-0-2047]**]

NOTE

If you address the ping to the IP broadcast address, the device lists the first four responses.

Observing LEDs

After you install the network cables, you can observe certain LEDs to determine if the network connections are functioning properly. The following table outlines the LEDs related to the network connections, the desired state of each LED, possible abnormal states of each LED, and what to do if an LED indicates an abnormal state.

TABLE 23 Network connection-related LED states

LED	Desired State	Meaning	Abnormal State	Meaning or Action
Ethernet(1-24/48) Link or Activity or Speed	On or Blinking (Green or Amber)	A link is established with the remote port and user packets are being transmitted or received.	Off	<p>A link is not established with the remote port. You can do the following:</p> <ul style="list-style-type: none"> Verify that the connection to the other network device has been properly made. Also, make certain that the other network device is powered on and operating correctly. Verify that the port has not been disabled through a configuration change. You can use the CLI. If you have configured an IP address on the device, you also can use the Brocade Network Advisor. For the combination ports (ports 1~4), check that the shared SFP port (1F~4F) is not being used. If the other actions don't resolve the problem, try using a different port or a different cable.

TABLE 23 Network connection-related LED states (Continued)

LED	Desired State	Meaning	Abnormal State	Meaning or Action
HPOE (1-24/48)	On Green	The port is providing HPOE power.	Off	A link is not established with the HPOE device. You can do the following: <ul style="list-style-type: none"> Verify that the connection to the other network device has been properly made. If the other actions don't resolve the problem, try using a different port or a different cable.
<hr/> <p>NOTE Note: FCX-E and FCX-I devices do not support HPOE</p> <hr/>				
SFP(1F~4F) Link or Activity	On Green	A link is established with the remote port.	Off	A link is not established with the remote port. You can do the following: <ul style="list-style-type: none"> Verify that the connection to the other network device has been properly made. Also, make certain that the other network device is powered on and operating correctly. Verify that the transmit port on the Brocade device is connected to the receive port on the other network device, and that the receive port on the Brocade device is connected to the transmit port on the other network device. If you are not certain, remove the two cable connectors from the port connector and reinsert them in the port connector, reversing their order. Dust may have accumulated in the cable connector or port connector. For information about cleaning the connectors, refer to Cleaning the fiber optic connectors on page 70. Verify that the port has not been disabled through a configuration change. Check that the configuration has not forced the use of the RJ45 port shared with the SFP port. If the other actions don't resolve the problem, try using a different port or a different cable.
SFP(1F~4F) Speed	On (Green or Amber)	A link is established with the remote port.	Off	A link is not established with the remote port. You can do the following: <ul style="list-style-type: none"> Check the Link LED to make sure the link is still established with the remote port. If not, take the actions described in the Meaning or Action column for the Link LED.

TABLE 23 Network connection-related LED states (Continued)

LED	Desired State	Meaning	Abnormal State	Meaning or Action
SFP+(1F~4F) Link or Activity	On Green	A link is established with the remote port.	Off	<p>A link is not established with the remote port. You can do the following:</p> <ul style="list-style-type: none"> Verify that the connection to the other network device has been properly made. Also, make certain that the other network device is powered on and operating correctly. Verify that the transmit port on the Brocade device is connected to the receive port on the other network device, and that the receive port on the Brocade device is connected to the transmit port on the other network device. If you are not certain, remove the two cable connectors from the port connector and reinsert them in the port connector, reversing their order. Dust may have accumulated in the cable connector or port connector. For information about cleaning the connectors, refer to Cleaning the fiber optic connectors on page 70. Verify that the port has not been disabled through a configuration change. Check that the configuration has not forced the use of the RJ45 port shared with the SFP port. If the other actions don't resolve the problem, try using a different port or a different cable.
SFP+(1F~4F) Speed	On (Green or Amber)	A link is established with the remote port.	Off	<p>A link is not established with the remote port. You can do the following:</p> <ul style="list-style-type: none"> Check the Link LED to make sure the link is still established with the remote port. If not, take the actions described in the Meaning or Action column for the Link LED.

If a problem persists after taking these actions, contact Brocade Technical Support.

Tracing a route

To determine the path through which a Brocade device can reach another device, enter a command similar to the following at any level of the CLI on the device.

```
device> traceroute 10.33.4.7
```

Syntax: `traceroute host-ip-addr [maxttl value] [minttl value] [numeric] [timeout value] [source-ip ip-addr]`

The CLI displays trace route information for each hop as soon as the information is received. Traceroute requests display all responses to a given TTL. In addition, if there are multiple equal-cost routes to the destination, the Brocade device displays up to two responses by default.

Troubleshooting network connections

- For the indicated port, verify that both ends of the cabling (at the device and the connected device) are snug.
- Verify that the device and the connected device are both powered on and operating correctly.
- Verify that you have used the correct cable type for the connection:
 - For twisted-pair connections to an end node, use straight-through cabling.
 - For fiber optic connections, verify that the transmit port on the device is connected to the receive port on the connected device, and that the receive port on the device is connected to the transmit port on the connected device.
- Use the CLI to verify that the port has not been disabled through a configuration change. If you have configured an IP address on the device, you also can use the Brocade Network Advisor.
- If the other procedures don't resolve the problem, try using a different port or a different cable.

Using Virtual Cable Testing to diagnose a cable

These devices support Virtual Cable Test (VCT) technology. VCT technology enables you to diagnose a conductor (wire or cable) by sending a pulsed signal into the conductor, then examining the reflection of that pulse. This method of cable analysis is referred to as Time Domain Reflectometry (TDR). By examining the reflection, the device can detect and report cable statistics such as local and remote link pair, cable length, and link status.

Configuration notes

- This feature is supported on copper ports only. It is not supported on fiber ports.
- The port to which the cable is connected must be enabled when you issue the command to diagnose the cable. If the port is disabled, the command is rejected.
- If the port is operating at 100 Mbps half-duplex, the TDR test on one pair will fail.
- If the remote pair is set to forced 100 Mbps, any change in MDI or MDIX may cause the device to interpret the Multilevel Threshold-3 (MLT-3) as a reflected pulse, in which case, the device will report a faulty condition. In this case, Brocade recommends that you run the TDR test a few times for accurate results.

Command syntax

To diagnose a cable using TDR, enter a command such as the following at the Privileged EXEC level of the CLI.

```
device# phy cable-diag tdr  
1/1/1
```

This command diagnoses the cable attached to port 1/1/1.

Syntax: `phy cable-diag tdrport-num`

Viewing the results of the cable analysis

To display the results of the cable analysis, enter a command similar to the following at the Privileged EXEC level of the CLI.

```
device# show cable-diag tdr 1/1/1
```

The output from this command appears below.

```
device# show cable-diag tdr 1/1/1
```

Port	Speed	Local pair	Pair Length	Remote pair	Pair status
1/1/1	1000M	Pair A	<50M	Pair B	Terminated
		Pair B	<50M	Pair A	Terminated
		Pair C	<50M	Pair D	Terminated
		Pair D	<50M	Pair C	Terminated

Syntax: show cable-diag tdrport-num

TABLE 24 Cable statistics

This Line...	Displays...
Port	The port that was tested.
Speed	The current line speed of the port.
Local pair	The local link name.
Pair Length	The cable length when terminated, or the distance to the point of fault when the line is not up.
Remote pair	The remote link name.
Pair status	The status of the link. This field displays one of the following: <ul style="list-style-type: none"> Terminated: The link is up. Shorted: A short is detected in the cable. Open: An opening is detected in the cable. ImpedMis: The impedance is mismatched. Failed: The TDR test failed.

Digital optical monitoring

You can configure your device to monitor optical transceivers in the system, either globally or by specified port. When this feature is enabled, the system monitors the temperature and signal power levels for the optical transceivers in the specified ports. Console messages and syslog messages are sent when optical operating conditions fall below or rise above the XFP, SFP, and SFP+ manufacturer's recommended thresholds. For more information about digital optical monitoring, refer to *FastIron Ethernet Switch Administration Guide*.

Managing the FCX Hardware

- [Managing temperature settings.....77](#)
- [Displaying FCX CPU usage..... 81](#)
- [Hardware maintenance schedule.....81](#)
- [Replacing a copper or fiber optic module.....81](#)



CAUTION

The procedures in this manual are for qualified service personnel.

Managing temperature settings

This section describes how to display temperature settings on the device and how to change the temperature warning and shutdown levels.

Using the temperature sensor

The device ships with three built-in temperature sensors that cause the device to generate a Syslog message and SNMP trap if the temperature exceeds a specified warning level or shutdown level. If the device temperature exceeds the safe threshold (shutdown level), the device will reboot.

The software reads the temperature sensors based on the device poll time, which is by default 60 seconds. If the temperature equals or exceeds the shutdown temperature for five consecutive polls by the software, the software will reboot the device to prevent damage.

You can use the CLI to perform the following tasks:

- Display the temperature of the device
- Change the warning and shutdown temperature levels
- Change the device poll time

Displaying the temperature

By default, the software polls the temperature sensor every 60 seconds to get the current temperature. This poll rate is controlled by the device poll time, which also controls how often the software polls other system components.

To display the temperature of a device, enter the **show chassis** command at any level of the CLI.

```
device# show chassis
The stack unit 1 chassis info:
Power supply 1 (NA - AC - Regular) present, status ok
Power supply 2 not present
Fan ok, speed (auto): [[1]]<->2<->3
Fan speed switching temperature thresholds:
  1 -> 2 @ 61 deg-C
  1 <- 2 @ 56 deg-C
  2 -> 3 @ 67 deg-C
  2 <- 3 @ 62 deg-C
```

```
MAC 1 Temperature Readings:
  Current temperature : 58.5 deg-C
CPU Temperature Readings:
  Current temperature : 52.0 deg-C
  Warning level.....: 75.0 deg-C
  Shutdown level.....: 90.0 deg-C
Boot Prom MAC : 0000.0000.0720
Management MAC: 0000.0000.0720
```

Syntax: show chassis

Displaying Syslog messages for temperature

The software sends a Syslog message and an SNMP trap if the temperature crosses the warning or shutdown thresholds. The following methods describe how to view the system log on the device. If you have configured the device to use a Syslog server or SNMP trap receiver, see the documentation for the server or receiver.

To display the system log, enter the **show log** command at any CLI level.

```
device# show log
Syslog logging: enabled (0 messages dropped, 0 flushes, 0 overruns)
Buffer logging: level ACDMEINW, 8 messages logged
level code: A=alert C=critical D=debugging M=emergency E=error
I=informational N=notification W=warning
Static Log Buffer:
Dynamic Log Buffer (50 entries):
at 0 days 0 hours 2 minutes 0 seconds, level alert
Temperature 48.0 C degrees, warning level 45.0 C degrees, shutdown level 55.0 C
degrees
at 0 days 0 hours 1 minutes 0 seconds, level alert
Temperature 40.0 C degrees, warning level 35.0 C degrees, shutdown level 45.0 C
degrees
```

Changing temperature warning and shutdown levels

The default warning temperatures and the default shutdown temperatures for the device are:

- Warning temperature is 85 Deg-C (measured on mainboard)
- Shutdown temperature is 90 Deg-C (measured on mainboard)

NOTE

These temperatures reflect the temperature of the board inside the device.

To change the temperature at which the device sends a warning, enter a command similar to the following at the Privileged EXEC level of the CLI:

```
device# temperature warning 1 85
```

Syntax: temperature warning *stack-id value*

The *stack-id* can be 1 - 8.

The *value* can be 0 - 125

```
device# temperature
  temperature          temperature sensor commands
device# temperature warning
  warning             Temperature at which the module sends a warning
device# temperature warning
  DECIMAL            Stack Number
device# temperature warning 1 87
device# show chassis
The stack unit 1 chassis info:
```

```

Power supply 1 (NA - AC - Regular) present, status ok
Power supply 2 not present
Fan ok, speed (auto): [[1]]<->2<->3
Fan speed switching temperature thresholds:
    1 -> 2 @ 61 deg-C
    1 <- 2 @ 56 deg-C
    2 -> 3 @ 67 deg-C
    2 <- 3 @ 62 deg-C
MAC 1 Temperature Readings:
    Current temperature : 58.5 deg-C
CPU Temperature Readings:
    Current temperature : 52.0 deg-C
    Warning level.....: 75.0 deg-C
    Shutdown level.....: 90.0 deg-C
Boot Prom MAC : 0000.0000.0720
Management MAC: 0000.0000.0720

```

Changing the shutdown temperature

You can change the shutdown temperature using the **fan-threshold** command as shown. The valid range is 0-125 deg-C.

```

device(config)# stack unit 1
device(config)# fan-threshold mp speed-3 62 95
device(config)# show chassis
The stack unit 1 chassis info:
Power supply 1 (NA - AC - Regular) present, status ok
Power supply 2 not present
Fan ok, speed (auto): [[1]]<->2<->3
Fan speed switching temperature thresholds:
    1 -> 2 @ 61 deg-C
    1 <- 2 @ 56 deg-C
    2 -> 3 @ 67 deg-C
    2 <- 3 @ 62 deg-C
MAC 1 Temperature Readings:
    Current temperature : 58.5 deg-C
CPU Temperature Readings:
    Current temperature : 52.0 deg-C
    Warning level.....: 75.0 deg-C
    Shutdown level.....: 90.0 deg-C
Boot Prom MAC : 0000.0000.0720
Management MAC: 0000.0000.0720

```

Syntax: **fan-threshold mp speed-3** *lowest-value highest-value*

The device will automatically reset and reload the software when the internal temperature reaches or exceeds the configured shutdown level for five minutes. The system is also capable of registering negative temperature settings.

To change the temperature at which the FastIron CX sends a warning, you must change the fan speed threshold. To view the current temperature thresholds, enter the **show chassis** command:

```

device# show chassis
The stack unit 1 chassis info:
Power supply 1 (NA - AC - Regular) present, status ok
Power supply 2 not present
Fan ok, speed (auto): [[1]]<->2<->3
Fan speed switching temperature thresholds:
    1 -> 2 @ 61 deg-C
    1 <- 2 @ 56 deg-C
    2 -> 3 @ 67 deg-C
    2 <- 3 @ 62 deg-C
MAC 1 Temperature Readings:
    Current temperature : 58.5 deg-C
CPU Temperature Readings:
    Current temperature : 52.0 deg-C
    Warning level.....: 75.0 deg-C
    Shutdown level.....: 90.0 deg-C
Boot Prom MAC : 0000.0000.0720
Management MAC: 0000.0000.0720

```

Enter a command to the following to change the temperature shutdown level from 80 deg-C to 90 deg-C.

```
device# stack unit 1
device(config-unit-1)# fan-threshold mp speed-3 50 90
```

Syntax: `fan-threshold mp speed-3 lowest-value highest-value`

The *value* can be 0 - 125.

Enter the **show chassis** command to confirm the change:

```
device# show chassis
The stack unit 1 chassis info:
Power supply 1 (NA - AC - Regular) present, status ok
Power supply 2 not present
Fan ok, speed (auto): [[1]]<->2<->3
Fan speed switching temperature thresholds:
    1 -> 2 @ 61 deg-C
    1 <- 2 @ 56 deg-C
    2 -> 3 @ 67 deg-C
    2 <- 3 @ 62 deg-C
MAC 1 Temperature Readings:
    Current temperature : 58.5 deg-C
CPU Temperature Readings:
    Current temperature : 52.0 deg-C
    Warning level.....: 75.0 deg-C
    Shutdown level
.....: 90.0 deg-C
Boot Prom MAC : 0000.0000.0720
Management MAC: 0000.0000.0720
```

Changing the temperature polling interval

The software reads the temperature sensor and polls other hardware sensors according to the value set for the poll time, which is 60 seconds by default. You can change the poll time using the CLI.

To change the poll time, enter a command similar to the following at the global CONFIG level:

```
device(config)# chassis poll-time 200
```

Syntax: `chassis poll-time value`

The *value* parameter is in seconds. It can be 0 - 65535.

Removing MAC address entries

You can remove the following types of learned MAC address entries from the system MAC address table:

- All MAC address entries
- All MAC address entries for a specified Ethernet port
- All MAC address entries for a specified VLAN
- A specified MAC address entry in all VLANs

For example, to remove entries for the MAC address 00-00-00 in all VLANs, enter the following command at the Privileged EXEC level of the CLI:

```
device# clear mac-address 00-00-00
```

Syntax: `clear mac-address { mac-address | ethernet port-num | vlan number }`

If you enter the **clear mac-address** command without any parameters, the software removes all MAC entries.

Use the *mac-address* parameter to remove a specified MAC address from all VLANs. Specify the MAC address in the following format: HHHH.HHHH.HHHH.

Use the **ethernet** *port-num* parameter to remove all MAC addresses for a specified Ethernet port.

Use the **vlan** *number* parameter to remove all MAC addresses for a specified VLAN.

Displaying FCX CPU usage

You can display the amount of the FCX CPU in use. To do so, enter the **show cpu** command at any level of the CLI:

```
device# show cpu
31 percent busy, from 3248 sec ago
1 sec avg: 10 percent busy
5 sec avg: 10 percent busy
60 sec avg: 10 percent busy
300 sec avg: 10 percent busy
```

Syntax: **show cpu**

Hardware maintenance schedule

FCX switch hardware components require minimal maintenance. Brocade recommends cleaning the fiber-optic connectors on a fiber-optic port and the connected fiber cable each time you disconnect the cable.

You can replace the copper and fiber optic modules (SFPs or mini-GBICs).

Replacing a copper or fiber optic module

You can remove an SFP from a slot and replace it with a new one while the FastIron CX is powered on and running.

This section provides information about the following tasks:

- Removing a copper or fiber optic module
- Installing a new copper or fiber optic module
- Cabling a fiber optic module

Removing a copper or fiber optic module

You can remove a copper or fiber SFP (also called a mini-GBIC) from a slot while the FastIron CX is powered on and running.

While removing a copper or fiber optic module, be sure to wear an ESD wrist strap with a plug for connection to the ESD connector on the FastIron CX.



CAUTION

For safety reasons, the ESD wrist strap should contain a series 1 meg ohm resistor.

To remove a copper or fiber optic module from an SFP slot, do the following.

1. Put on the ESD wrist strap and ground yourself by attaching the clip end to a metal surface (such as an equipment rack).
2. Disconnect the copper or fiber cable connector from the port connector.
3. Unlock the copper or fiber optic module by pulling the bail latch forward, away from the front panel of the module.

On 1000BaseSX ports, the bail latch is enclosed in a black sleeve, and on 1000BaseLX ports, the bail latch is enclosed in a blue sleeve.

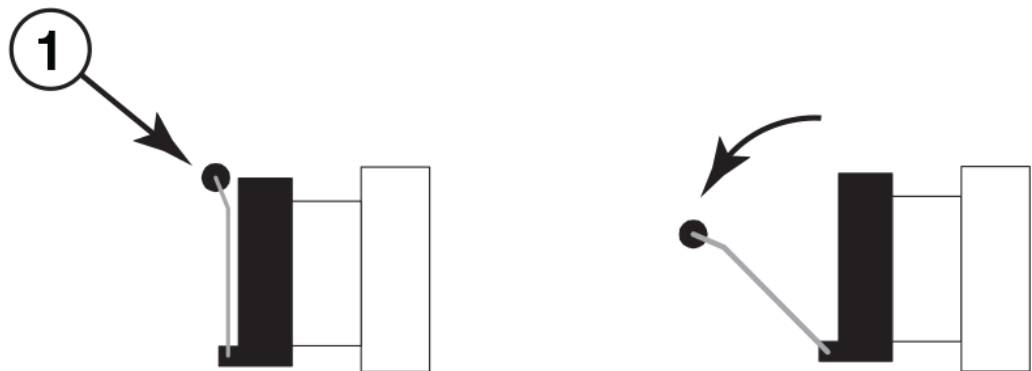

1 Bail Latch

FIGURE 47 Unlocking the bail latch

NOTE

The bail latch may be attached to either the top or the bottom of the mini-GBIC.

4. Grasp the bail latch and pull the copper or fiber optic module out of the port.

FIGURE 48 Remove fiber optic module

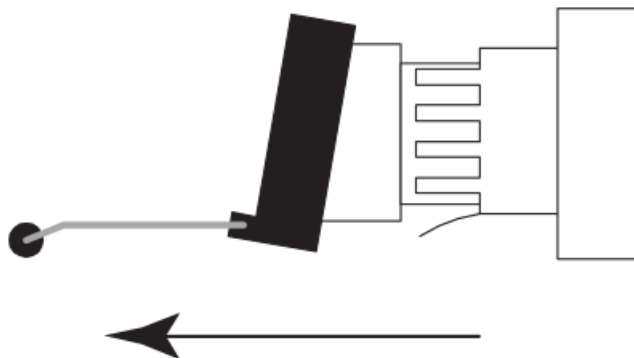

5. Store the copper or fiber optic module in a safe, static-free place or in an anti-static bag.
6. Install a new copper or fiber optic module in the port.

Cabling a fiber optic module

For instructions on cabling a fiber optic module refer to [Cabling a fiber optic transceiver](#) on page 70.

Cleaning the fiber optic connectors

For instructions on cleaning a fiber optic module refer to [Cleaning the fiber optic connectors](#) on page 70.

Hardware Specifications

- [Hardware specifications](#)..... 85

Hardware specifications

This chapter provides the hardware specifications for FastIron CX devices.

Physical dimensions and weight

TABLE 25 Physical dimensions and weight

Model	Height	Width	Depth	Weight
Brocade FCX 624S, Brocade FCX 648S, Brocade FCX 624S-F	4.4 cm1.7 in	44 cm17.32 in	38.6 cm15.19 in	4 kg (8.8 lbs)
Brocade FCX 624S-HPOE, Brocade FCX 648S-HPOE	4.4 cm1.7 in	44 cm17.32 in	44 cm17.32 in	4.5 kg (9.9 lbs)
Brocade FCX 624-E Brocade FCX 624-I	4.4 cm1.7 in	44 cm17.32 in	43.5 cm17.13 in	5.35 kg (11.79 lbs)
Brocade FCX 648-E Brocade FCX 648-I	4.4 cm1.7 in	44 cm17.32 in	43.5 cm17.13 in	5.71 kg (12.59 lbs)

Environmental considerations

For optimal performance, operate or store your device in compliance with the following environmental conditions.

Operating Environment

TABLE 26 Operating environment

Operating Temperature	Relative Humidity	Operating Altitude
0° - 40° C (32° - 104° F)	5 to 95%, @ 40° C (104.9°F), non-condensing	0 - 3000 meters (10,000 feet)

Storage environment**TABLE 27** Storage environment specifications

Storage Temperature	Storage Humidity	Storage Altitude
40× to 70× C (-40× to 158× F)	95% maximum, non-condensing	3,000 meter (10,000 feet) maximum

Cooling system and fans

The fans cool the CPU, main memory, and voltage regulators. For the Brocade FCX 624S, FCX 648S, FCX 624S-F, FCX 624S-HPOE, and FCX 648S-HPOE switches, the fans use either a push or pull configuration to move the air from the right side of the device to the left side of the device.

- Total cooling capacity: 80 to 130 watts
- Total air flow: 34.3 CFM
- Operating noise: ideal 51 dB-A

For the Brocade FCX 624-E and FCX 648-E models, the air flows from the front to the rear of the device. For the Brocade FCX 624-I and Brocade FCX 648-I models, the air flows from the rear to the front of the device.

- Total cooling capacity: 180 Watts
- Total air flow: 85.2 CFM
- Operating noise: ideal 60 dB-A

NOTE

Operating noise is based on the ISO 7779 standard.

**CAUTION**

For the FCX624-E, FCX624-I, FCX648-E, and FCX648-I devices, be sure that the airflow direction of the power supply unit matches that of the installed fan tray. The power supplies and fan trays are clearly labeled with either a green arrow with an "E", or an orange arrow with an "I".

FIGURE 49 Brocade FCX 624S, FCX 648S, FCX 624S-F, FCX 624S-HPOE, and FCX 648S-HPOE device airflow

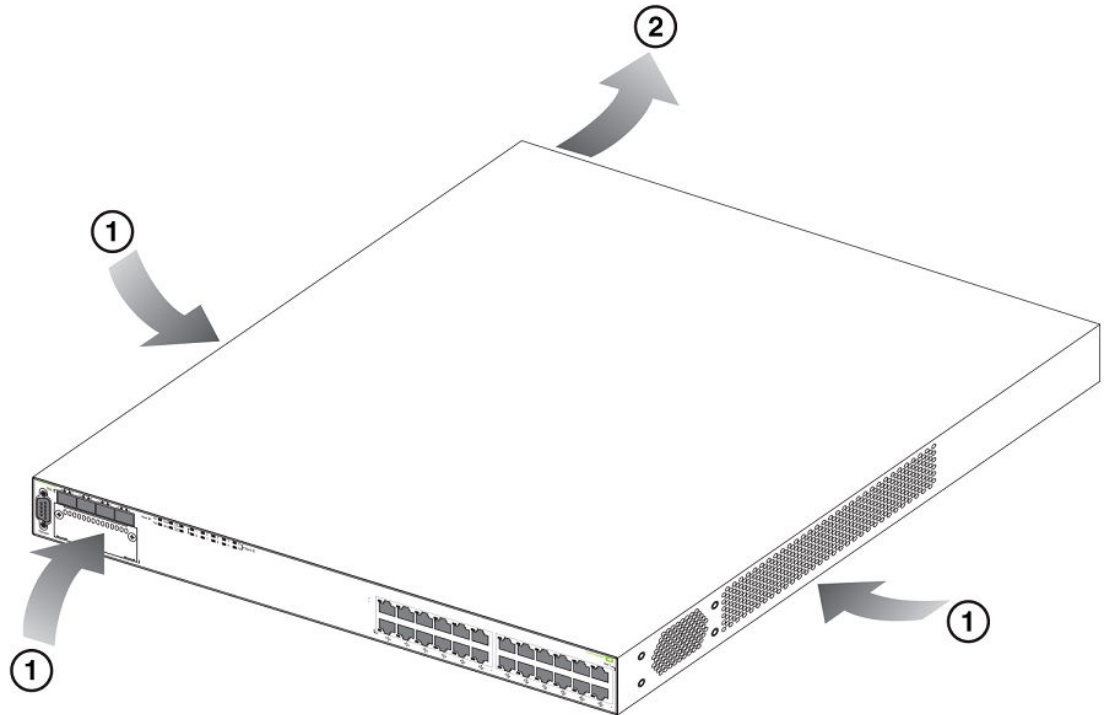

- 1. Air inflow
- 2. Air outlet

FIGURE 50 Brocade FCX 624-E and Brocade FCX 648-E device airflow

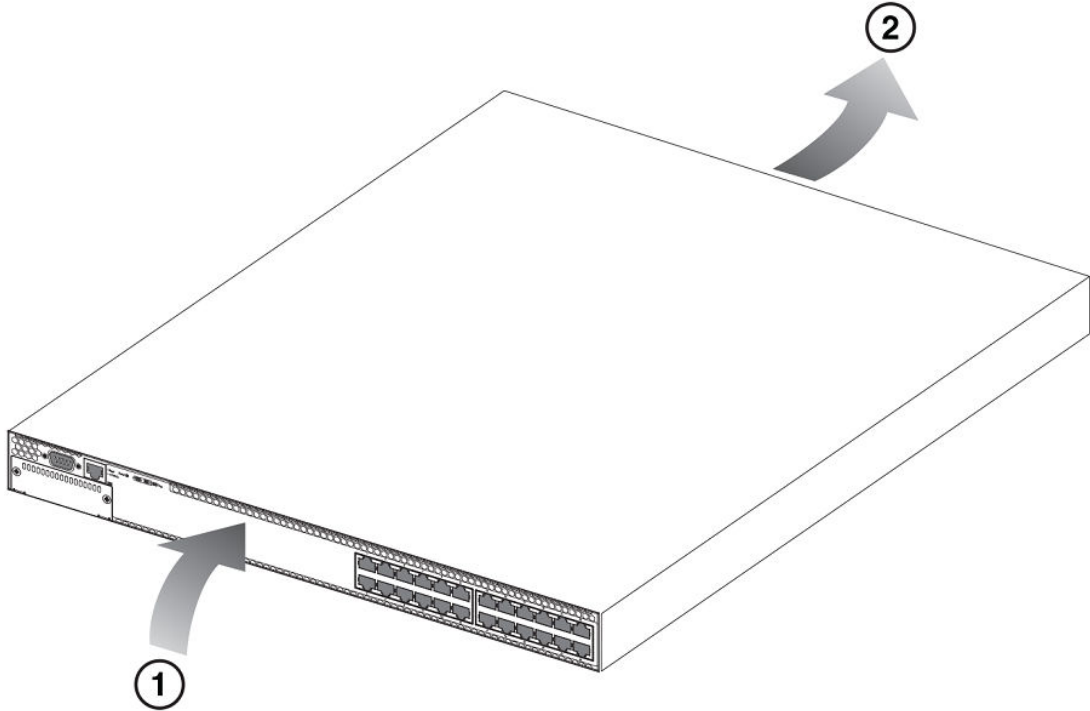

1. Air inflow
2. Air outlet

FIGURE 51 Brocade FCX 624-I and Brocade FCX 648-I device airflow

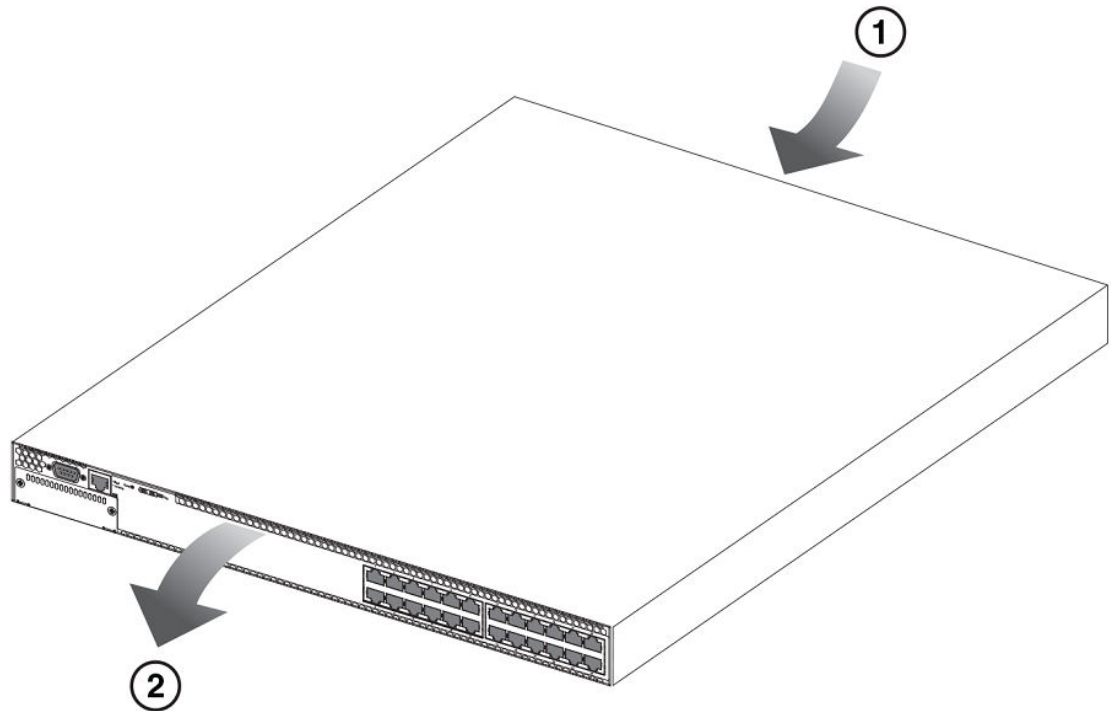

1. Air inflow
2. Air outlet

For a complete list of regulatory compliances refer to the Regulatory Statements section.

Pinouts and signalling

This section describes the pinout diagrams for the DB-9 connector and RJ45 port jacks.

Serial (Console) port pinouts

The Console port is a standard male DB-9 connector.

FIGURE 52 Serial port pinouts

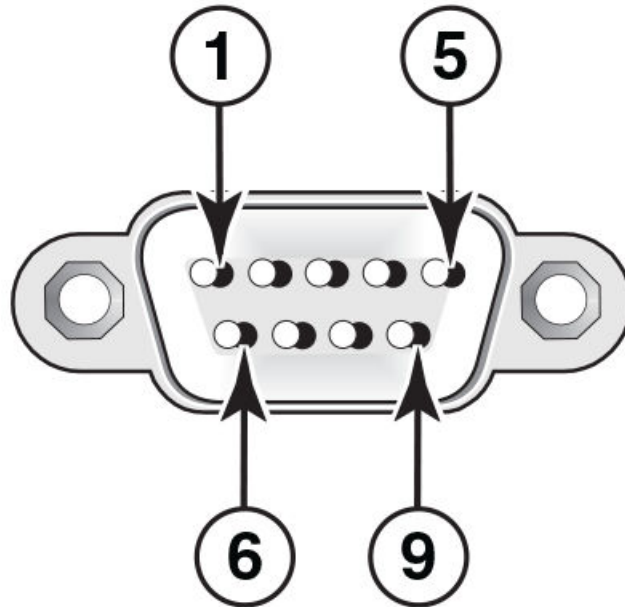

Most PC serial ports require a cable with a female DB-9 connector. However, terminal connections will vary, requiring a cable with either a DB-9 or DB-25 connector, male or female.

NOTE

Some of the wires should not be connected. If you do connect the wires that are labeled "Reserved", you may get unexpected results with some terminals.

FIGURE 53 Console port pin assignments showing cable connection options to a terminal or PC

DB-9 to DB-9 Female Switch		Terminal or PC	DB-9 to DB-25 Female Switch		Terminal or PC
1	Reserved	1	1	Reserved	8
2	→	2	2	→	3
3	←	3	3	←	2
4	Reserved	4	4	Reserved	20
5	→	5	5	→	7
6	Reserved	6	6	Reserved	6
7	←	7	7	←	4
8	→	8	8	→	5
9	Reserved	9	9	Reserved	22

FIGURE 54 Pin assignment and signalling for 10/100BaseTX and 1000BaseT ports

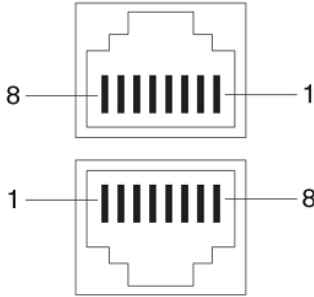
Pin Assignment	10BaseT Pin Number	MDI-X ports	100BaseTX and 1000BaseT Pin Number	MDI-X ports
	1	RD+	1	RD+
	2	RD-	2	RD-
	3	TD+	3	TD+
	4	Not used	4	CMT
	5	Not used	5	CMT
	6	TD-	6	TD-
	7	Not used	7	CMT
	8	Not used	8	CMT

Cable specifications

This section lists the specifications for the cables used with the 10/100 Ethernet ports. For information about supported transceivers, see [Fiber Optic transceivers](#) on page 67.

For information about supported SFP and SFP+ transceivers, refer to the following Brocade website:

http://www.brocade.com/downloads/documents/data_sheets/product_data_sheets/Optics_DS.pdf

NOTE

Cable installation and network configuration will affect overall transmission capability. The numbers provided below represent the accepted recommendations of the various standards. For network-specific recommendations, consult your local Brocade reseller or system engineer.

TABLE 28 Cable length summary

	Cable Type	Connector Type	Core Diameter(microns)	Modal Bandwidth(MHz*km) or Wavelength (nm)	Range (meters)
1000Base-BX-D	Single-mode Fiber (SMF)	LC connector for SFP module	9	1490 nm	2 - 10000 (10km)
1000Base-BX-U	SMF	LC connector for SFP module	9	1310 nm	2 - 10000 (10km)
1000Base-LHA	SMF	LC connector for SFP module	9	1550 nm	2 - 70000 (70km)
1000Base-LHB	SMF	LC connector for SFP module	9	1550 nm	2 - 120000 (120km)

TABLE 28 Cable length summary (Continued)

	Cable Type	Connector Type	Core Diameter(microns)	Modal Bandwidth(MHz*km) or Wavelength (nm)	Range (meters)
1000Base-LX	Multi-mode Fiber (MMF)	LC connector for SFP module	62.5	500	2 - 550
	MMF		50	400	2 - 550
	MMF		50	500	2 - 550
	SMF		9	1300 nm	2 - 10000
1000Base-SX	MMF	LC connector for SFP module	62.5/125	200	.5 - 275
	MMF		62.5/125	500	.5 - 550
	MMF		50/125	900	.5 - 595
	MMF		50/125	1500	.5 - 740
	MMF		50/125	2000	.5 - 860
1000Base-T	Copper	RJ-45 jack for standard unshielded twisted pair (UTP or Category 5)	n/a	n/a	up to 100 meters
100Base-FX	MMF	LC connector for SFP module	62.5	500	up to 2000 (2 km)
100Base-FX-IR	MMF	SC	62.5	125	2 km (1.24 miles)
100Base-FX-LR	SMF	SC	9	125	20 km (12.43 miles)
10GBase-CX4	Infiniband 4x copper	XAUI connector	n/a	n/a	up to 15
10G SFP+	TW NX	SFP	n/a	n/a	1, 3, and 5

Power cords

All devices ship with US-compatible power cords unless otherwise specified at the time of order. United Kingdom- and European-compatible power cords are also available.

AC power supply specifications

All devices ship with one removable AC power supply unit with a standard IEC type (IEC320) input connector, operating 100 VAC to 240 VAC input, universal or wide input.

NOTE

For HPOE+ Class 4 power usage, FCX devices with two power supplies can only support up to 27 HPOE ports. For Class 1, 2, or 3 power usage, these devices can support up to 48 ports.

TABLE 29 AC power supply specifications

	Input voltage range	Input current(PSU x 1)	Inrush current	Power draw	Max output power (PSU x1)
Brocade FCX 624S	100 - 240 VAC	1.2 - 2.8 Amps	< 75 Amps peak maximum	94 W	210 W
Brocade FCX 648S	100 - 240 VAC	1.2 - 2.8 Amps	< 75 Amps peak maximum	122 W	210 W
Brocade FCX 624S-HPOE	100 - 240 VAC	3.3 - 7.8 Amps	< 75 Amps peak maximum	107 W/509 W with HPOE/509 W with HPOE+	620 W
Brocade FCX 648S-HPOE	100 - 240 VAC	3.3 - 7.8 Amps	< 75 Amps peak maximum	167 W/970 W with HPOE/970 W with HPOE+	620 W
Brocade FCX 624S-F	100 - 240 VAC	1.2 - 2.8 Amps	< 75 Amps peak maximum	102.1 W	210 W
Brocade FCX 624-E	100 - 240 VAC	1.2 - 2.8 Amps	< 75 Amps peak maximum	92 W	210 W
Brocade FCX 624-I	100 - 240 VAC	1.2 - 2.8 Amps	< 75 Amps peak maximum	92 W	210 W
Brocade FCX 648-E	100 - 240 VAC	1.2 - 2.8 Amps	< 75 Amps peak maximum	112 W	210 W
Brocade FCX 648S	100 - 240 VAC	1.2 - 2.8 Amps	< 75 Amps peak maximum	112 W	210 W

Troubleshooting

- [Diagnosing switch indicators 95](#)

Diagnosing switch indicators

TABLE 30 Troubleshooting chart

Symptom	Action
Power LED is Off	<ul style="list-style-type: none">• Internal power supply is disconnected.• Check connections between the switch, the power cord, and the wall outlet.• Contact Technical Support.
Power LED is Amber	Internal power supply has failed. Contact Technical Support.
Diag LED is Amber	<ul style="list-style-type: none">• The switch self test has detected a fault.• Power cycle the switch to try and clear the condition. If the condition persists, contact Technical Support.
Link LED is Off	<ul style="list-style-type: none">• Verify that the switch and attached device are powered on.• Be sure the cable is plugged into both the switch and corresponding device.• Verify that the proper cable type is used and its length does not exceed specified limits.• Check the adapter on the attached device and cable connections for possible defects. Replace the defective adapter or cable if necessary.

Power and cooling problems

If the power indicator does not turn on when the power cord is plugged in, you may have a problem with the power outlet, power cord, or internal power supply. However, if the unit powers off after running for a while, check for loose power connections, power losses or surges at the power outlet, and verify that the fans on the unit are unobstructed and running prior to shutdown. If you still cannot isolate the problem, then the internal power supply may be defective. In this case, contact Technical Support for assistance.

Installation

Verify that all system components have been properly installed. If one or more components appear to be malfunctioning (such as the power cord or network cabling), test them in an alternate environment where you are sure that all the other components are functioning properly.

In-band access

You can access the management agent in the switch from anywhere within the attached network using Telnet, a Web browser, or other network management software. However, you must first configure the

switch with a valid IP address, subnet mask, and default gateway. If you have trouble establishing a link to the management agent, check to see if you have a valid network connection. Then verify that you entered the correct IP address. Also, be sure the port through which you are connecting to the switch has not been disabled. If it has not been disabled, then check the network cabling that runs between your remote location and the switch.

Regulatory Statements

- USA (FCC CFR 47 Part 15 Warning).....97
- Industry Canada statement.....97
- Europe and Australia (CISPR 22 Class A Warning).....98
- Germany (Noise Warning).....98
- Japan (VCCI).....98
- Japan power cord.....98
- Korea.....99
- China.....100
- BSMI statement (Taiwan).....100
- Regulatory compliance.....101

USA (FCC CFR 47 Part 15 Warning)

This equipment has been tested and found to comply with the limits for a Class A digital device pursuant to Part 15 of the FCC Rules. These limits are designed to provide reasonable protection against harmful interference when the equipment is operated in a commercial environment. This equipment generates, uses, and can radiate radio frequency energy and, if not installed and used in accordance with the instruction manual, may cause harmful interference to radio communications. Operation of this equipment in a residential area is likely to cause harmful interference in which case the user will be required to correct the interference at his own expense.



CAUTION

Changes or modifications made to this device which are not expressly approved by the party responsible for compliance could void the authority of the user to operate the equipment.

Industry Canada statement

Cet appareil numérique de la classe A est conforme à la norme NMB-003 du Canada.

English translation of above statement

This Class A digital apparatus complies with Canadian ICES-003.

Europe and Australia (CISPR 22 Class A Warning)

This is a Class A product. In a domestic environment this product may cause radio interference in which case the user may be required to take adequate measures.

Germany (Noise Warning)

Machine noise information regulation - 3. GPSGV, the highest sound pressure level value is 70.0 dB(A) in accordance with EN ISO 7779.

Maschinenlärminformations-Verordnung - 3. GPSGV, der höchste Schalldruckpegel beträgt 70.0 dB(A) gemäss EN ISO 7779.

Japan (VCCI)

この装置は、情報処理装置等電波障害自主規制協議会 (VCCI) の基準に基づくクラス A 情報技術装置です。この装置を家庭環境で使用すると電波妨害を引き起こすことがあります。この場合には使用者が適切な対策を講ずるよう要求されることがあります。

English translation of above statement

This is Class A product based on the standard of the Voluntary Control Council For Interference by Information Technology Equipment (VCCI). If this equipment is used in a domestic environment, radio disturbance may arise. When such trouble occurs, the user may be required to take corrective actions.

Japan power cord



注意 - 添付の電源コードを他の装置や用途に使用しない

添付の電源コードは本装置に接続し、使用することを目的として設計され、その安全性が確認されているものです。決して他の装置や用途に使用しないでください。火災や感電の原因となる恐れがあります。

English translation of above statement

ATTENTION: Never use the power cord packed with your equipment for other products.

Korea

A급 기기(업무용 방송통신기기): 이 기기는 업무용(A급)으로 전자파적합등록을 한 기기이오니 판매자 또는 사용자는 이 점을 주의하시기 바라며, 가정외의 지역에서 사용하는 것을 목적으로 합니다.

English translation of above statement

Class A device (Broadcasting Communication Device for Office Use): This device obtained EMC registration for office use (Class A), and may be used in places other than home. Sellers and/or users need to take note of this.

English translation of above statement

Warning: This is a class A product. In a domestic environment this product may cause radio interference in which case the user may be required to take adequate measures.

Regulatory compliance

The table below lists the Electromagnetic Compatibility (EMC), Immunity standards, and safety agency approvals for the FastIron family of switches.

TABLE 31 Regulatory compliance and safety approvals

Certifications

Emissions:

- ICES-003, Electromagnetic Emission
- FCC Part 15 Class A
- EN 55022/CISPR 22 Class A
- VCCI Class A
- EN 61000-3-2, Power Line Harmonics
- EN 61000-3-3, Voltage Fluctuation & Flicker
- EN 61000-6-3, Electromagnetic Compatibility, Generic Standard
- AS or NZS CISPR 22, Electromagnetic Compatibility

Immunity:

- EN 61000-6-1, Electromagnetic Compatibility, Generic Standard
- EN 55024, Information Technology equipment - Immunity Characteristics

Safety:

- BI-NAT CSA 60950-1-07/UL 60950-1 Second Edition
 - EN 60950-1:2006
 - IEC 60950-1:2005
-

Cautions and Danger Notices

- [Cautions](#)..... 103
- [Danger notices](#)..... 107

Cautions

A caution calls your attention to a possible hazard that can damage equipment.

"Vorsicht" weist auf die Gefahr einer möglichen Beschädigung des Gerätes in.

Une mise en garde attire votre attention sur un risque possible d'endommagement de l'équipement. Ci-dessous, vous trouverez les mises en garde utilisées dans ce manuel.

Un mensaje de precaución le advierte sobre un posible peligro que pueda dañar el equipo. Las siguientes son precauciones utilizadas en este manual.

CAUTION	Do not install the device in an environment where the operating ambient temperature might exceed 40°C (104°F).
VORSICHT	Das Gerät darf nicht in einer Umgebung mit einer Umgebungsbetriebstemperatur von über 40°C (104°F) installiert werden.
MISE EN GARDE	N'installez pas le dispositif dans un environnement où la température d'exploitation ambiante risque de dépasser 40°C (104°F).
PRECAUCIÓN	No instale el instrumento en un entorno en el que la temperatura ambiente de operación pueda exceder los 40°C (104°F).

CAUTION	Make sure the airflow around the front, sides, and back of the device is not restricted.
VORSICHT	Stellen Sie sicher, dass an der Vorderseite, den Seiten und an der Rückseite der Luftstrom nicht behindert wird.
MISE EN GARDE	Vérifiez que rien ne restreint la circulation d'air devant, derrière et sur les côtés du dispositif et qu'elle peut se faire librement.
PRECAUCIÓN	Asegúrese de que el flujo de aire en las inmediaciones de las partes anterior, laterales y posterior del instrumento no esté restringido.

CAUTION	Use a separate branch circuit for each AC power cord, which provides redundancy in case one of the circuits fails.
VORSICHT	Es empfiehlt sich die Installation eines separaten Stromkreisweiges für jede Wechselstrom-Elektroschnur als Redundanz im Fall des Ausfalls eines Stromkreises.

CAUTION	Use a separate branch circuit for each AC power cord, which provides redundancy in case one of the circuits fails.
MISE EN GARDE	Utilisez un circuit de dérivation différent pour chaque cordon d'alimentation C.A. Ainsi, il y aura un circuit redondant en cas de panne d'un des circuits.
PRECAUCIÓN	Use un circuito derivado separado para cada cordón de alimentación de CA, con lo que se proporcionará redundancia en caso de que uno de los circuitos falle.
CAUTION	Ensure that the device does not overload the power circuits, wiring, and over-current protection. To determine the possibility of overloading the supply circuits, add the ampere (amp) ratings of all devices installed on the same circuit as the device. Compare this total with the rating limit for the circuit. The maximum ampere ratings are usually printed on the devices near the input power connectors.
VORSICHT	Stromkreise, Verdrahtung und Überlastschutz dürfen nicht durch das Gerät überbelastet werden. Addieren Sie die Nennstromleistung (in Ampere) aller Geräte, die am selben Stromkreis wie das Gerät installiert sind. Somit können Sie feststellen, ob die Gefahr einer Überbelastung der Versorgungsstromkreise vorliegt. Vergleichen Sie diese Summe mit der Nennstromgrenze des Stromkreises. Die Höchstnennströme (in Ampere) stehen normalerweise auf der Geräterückseite neben den Eingangsstromanschlüssen.
MISE EN GARDE	Assurez-vous que le dispositif ne risque pas de surcharger les circuits d'alimentation, le câblage et la protection de surintensité. Pour déterminer le risque de surcharge des circuits d'alimentation, additionnez l'intensité nominale (ampères) de tous les dispositifs installés sur le même circuit que le dispositif en question. Comparez alors ce total avec la limite de charge du circuit. L'intensité nominale maximum en ampères est généralement imprimée sur chaque dispositif près des connecteurs d'entrée d'alimentation.
PRECAUCIÓN	Verifique que el instrumento no sobrecargue los circuitos de corriente, el cableado y la protección para sobrecargas. Para determinar la posibilidad de sobrecarga en los circuitos de suministros, añada las capacidades nominales de corriente (amp) de todos los instrumentos instalados en el mismo circuito que el instrumento. Compare esta suma con el límite nominal para el circuito. Las capacidades nominales de corriente máximas están generalmente impresas en los instrumentos, cerca de los conectores de corriente de entrada.
CAUTION	Use the erase startup-config command only for new systems. If you enter this command on a system you have already configured, the command erases the configuration. If you accidentally do erase the configuration on a configured system, enter the write memory command to save the running configuration to the startup-config file.
VORSICHT	Verwenden Sie den Befehl " Erase startup-config " (Löschen Startup-Konfig) nur für neue Systeme. Wenn Sie diesen Befehl in ein bereits konfiguriertes System eingeben, löscht der Befehl die Konfiguration. Falls Sie aus Versehen die Konfiguration eines bereits konfigurierten Systems löschen, geben Sie den Befehl " Write Memory " (Speicher schreiben) ein, um die laufende Konfiguration in der Startup-Konfig-Datei zu speichern.
MISE EN GARDE	N'utilisez la commande erase startup-config que pour les nouveaux systèmes. Si vous entrez cette commande sur un système que vous avez déjà configuré, elle efface la configuration. Si vous effacez la configuration par accident sur un système configuré, entrez la commande write memory pour enregistrer la configuration actuelle dans le fichier startup-config.

CAUTION Use the **erase startup-config** command only for new systems. If you enter this command on a system you have already configured, the command erases the configuration. If you accidentally do erase the configuration on a configured system, enter the **write memory** command to save the running configuration to the startup-config file.

PRECAUCIÓN Use el comando **erase startup-config** (borrar configuración de inicio) para sistemas nuevos solamente. Si usted introduce este comando en un sistema que ya ha configurado, el comando borrará la configuración. Si usted borra accidentalmente la configuración en un sistema ya configurado, introduzca el comando **write memory** (escribir memoria) para guardar la configuración en ejecución en el archivo startup-config.

CAUTION Never leave tools inside the chassis.

VORSICHT Lassen Sie keine Werkzeuge im Chassis zurück.

MISE EN GARDE Ne laissez jamais d'outils à l'intérieur du châssis.

PRECAUCIÓN No deje nunca herramientas en el interior del chasis.

CAUTION Changes or modifications made to this device that are not expressly approved by the party responsible for compliance could void the user's authority to operate the equipment.

VORSICHT Falls dieses Gerät verändert oder modifiziert wird, ohne die ausdrückliche Genehmigung der für die Einhaltung der Anforderungen verantwortlichen Partei einzuholen, kann dem Benutzer der weitere Betrieb des Gerätes untersagt werden.

MISE EN GARDE Les éventuelles modifications apportées à cet équipement sans avoir été expressément approuvées par la partie responsable d'en évaluer la conformité sont susceptibles d'annuler le droit de l'utilisateur à utiliser cet équipement.

PRECAUCIÓN Si se realizan cambios o modificaciones en este dispositivo sin la autorización expresa de la parte responsable del cumplimiento de las normas, la licencia del usuario para operar este equipo puede quedar anulada.

CAUTION Risk of explosion if battery is replaced by an incorrect type. Dispose of used batteries according to the instructions.

VORSICHT Es besteht Explosionsgefahr, wenn ein unzulässiger Batterietyp eingesetzt wird.
Verbrauchte Batterien sind entsprechend den geltenden Vorschriften zu entsorgen.

MISE EN GARDE Risque d'explosion en cas de remplacement de la pile par un modèle incorrect.
Débarrassez-vous des piles usagées conformément aux instructions.

PRECAUCIÓN Riesgo de explosión si se sustituye la batería por una de tipo incorrecto. Deshágase de las baterías usadas de acuerdo con las instrucciones.

CAUTION	Ensure that adequate ventilation is provided for the system. A 3 cm clearance is recommended above the device and 8 cm clearance is recommended on each side.
VORSICHT	Assurez-vous que le circuit est correctement ventilé. Il est recommandé de conserver un espace de 3 cm au-dessus du dispositif, et de 8 cm sur chaque côté.
MISE EN GARDE	Stellen Sie sicher, dass das System ausreichend belüftet wird. Über dem Gerät wird 3 cm Freiraum, auf beiden Seiten jeweils 8 cm Freiraum empfohlen.
PRECAUCIÓN	Asegúrese de proporcionar una ventilación adecuada al sistema. Se recomienda dejar 3 cm de espacio libre por encima del dispositivo y 8 cm a cada lado.
CAUTION	Do not mount the ICX 6430-C device directly underneath a desktop surface with the top panel facing downward. Only mount the ICX 6430-C device underneath a desktop by attaching it to the metal side surface of the desk, with the front panel and ports facing downward.
VORSICHT	N'installez pas le dispositif ICX 6430-C directement sous une surface de bureau, en orientant la face supérieure vers le bas. Faites-le uniquement en le plaçant sous un bureau et en le reliant à la surface latérale métallique du bureau, en orientant la face avant et les ports vers le bas.
MISE EN GARDE	Installieren Sie den ICX 6430-C nicht über Kopf (Oberseite weist nach unten) direkt unter einer Tischplatte. Der ICX 6430-C darf nur unter einer Tischplatte installiert werden, indem er an der metallenen Seitenwand des Schreibtisches befestigt wird, wobei die Vorderseite und die Anschlüsse nach unten weisen.
PRECAUCIÓN	No monte el dispositivo ICX 6430-C directamente debajo de la superficie de un escritorio con el panel superior orientado hacia abajo. Solo se debe montar el dispositivo ICX 6430-C debajo de la superficie de un escritorio sujetándolo a la superficie lateral metálica del escritorio, con el panel frontal y los puertos orientados hacia abajo.
CAUTION	The magnet sheet can only be placed against the bottom panel of the device. Do not attempt to attach the magnet sheet to any other panels on the device.
VORSICHT	Il est uniquement possible de placer la feuille magnétique contre la face inférieure du dispositif. Ne tentez pas de placer la feuille magnétique à d'autres endroits.
MISE EN GARDE	Die magnetische Matte kann nur an der Unterseite des Geräts angebracht werden. Versuchen Sie nicht, die magnetische Matte an den anderen Seiten des Geräts anzubringen.
PRECAUCIÓN	La hoja magnética solo se puede colocar sobre el panel inferior del dispositivo. No intente conectar la hoja magnética a ningún otro panel del dispositivo.
CAUTION	Before plugging a cable to any port, be sure to discharge the voltage stored on the cable by touching the electrical contacts to ground surface.
VORSICHT	Avant de brancher un câble à un port, assurez-vous de décharger la tension du câble en reliant les contacts électriques à la terre.
MISE EN GARDE	Bevor Sie ein Kabel in einen Anschluss einstecken, entladen Sie jegliche im Kabel vorhandene elektrische Spannung, indem Sie mit den elektrischen Kontakten eine geerdete Oberfläche berühren.

CAUTION Before plugging a cable to any port, be sure to discharge the voltage stored on the cable by touching the electrical contacts to ground surface.

PRECAUCIÓN Antes de conectar un cable en cualquier puerto, asegúrese de descargar la tensión acumulada en el cable tocando la superficie de conexión a tierra con los contactos eléctricos.

Danger notices

A danger notification calls your attention to a possible hazard that can cause injury or death. The following are the warnings used in this manual.

"Gefahr" weist auf eine mögliche Gefährdung hin, die zu Verletzungen oder Tod führen können. Sie finden die folgenden Warnhinweise in diesem Handbuch.

Un danger attire votre attention sur un risque possible de blessure ou de décès. Ci-dessous, vous trouverez les avertissements utilisés dans ce manuel.

Una señal de peligro le llama la atención sobre cualquier posible peligro que pueda ocasionar daños personales o la muerte. A continuación se dan las advertencias utilizadas en este manual.

DANGER The procedures in this manual are for qualified service personnel.

GEFAHR Die Verfahren in diesem Handbuch sind nur für qualifiziertes Wartungspersonal gedacht.

DANGER Les procédures décrites dans ce manuel doivent être effectuées par le personnel de service qualifié uniquement.

PELIGRO Los procedimientos de este manual se han hecho para personal de servicio cualificado.

DANGER Before beginning the installation, see the precautions in "Power precautions."

GEFAHR Vor der Installation siehe Vorsichtsmaßnahmen unter "Power Precautions" (Vorsichtsmaßnahmen in Bezug auf elektrische Ablagen).

DANGER Avant de commencer l'installation, consultez les précautions décrites dans "Power Precautions" (Précautions quant à l'alimentation).

PELIGRO Antes de comenzar la instalación, consulte las precauciones en la sección "Power Precautions" (Precauciones sobre corriente).

DANGER All fiber-optic interfaces use Class 1 lasers.

GEFAHR Alle Glasfaser-Schnittstellen verwenden Laser der Klasse 1.

DANGER Toutes les interfaces en fibres optiques utilisent des lasers de classe 1.

PELIGRO Todas las interfaces de fibra óptica utilizan láser de clase 1.

DANGER Make sure the rack or cabinet housing the device is adequately secured to prevent it from becoming unstable or falling over.

GEFAHR Stellen Sie sicher, dass das Gestell oder der Schrank für die Unterbringung des Geräts auf angemessene Weise gesichert ist, so dass das Gestell oder der Schrank nicht wackeln oder umfallen kann.

DANGER Vérifiez que le bâti ou le support abritant le dispositif est bien fixé afin qu'il ne devienne pas instable ou qu'il ne risque pas de tomber.

PELIGRO Verifique que el bastidor o armario que alberga el instrumento está asegurado correctamente para evitar que pueda hacerse inestable o que caiga.

DANGER Mount the devices you install in a rack or cabinet as low as possible. Place the heaviest device at the bottom and progressively place lighter devices above.

GEFAHR Montieren Sie die Geräte im Gestell oder Schrank so tief wie möglich. Platzieren Sie das schwerste Gerät ganz unten, während leichtere Geräte je nach Gewicht (je schwerer desto tiefer) darüber untergebracht werden.

DANGER Montez les dispositifs que vous installez dans un bâti ou support aussi bas que possible. Placez le dispositif le plus lourd en bas et le plus léger en haut, en plaçant tous les dispositifs progressivement de bas en haut du plus lourd au plus léger.

PELIGRO Monte los instrumentos que instale en un bastidor o armario lo más bajos posible. Ponga el instrumento más pesado en la parte inferior y los instrumentos progresivamente más livianos más arriba.

DANGER Disconnect the power cord from all power sources to completely remove power from the device.

GEFAHR Ziehen Sie das Stromkabel aus allen Stromquellen, um sicherzustellen, dass dem Gerät kein Strom zugeführt wird.

DANGER Débranchez le cordon d'alimentation de toutes les sources d'alimentation pour couper complètement l'alimentation du dispositif.

PELIGRO Para desconectar completamente la corriente del instrumento, desconecte el cordón de corriente de todas las fuentes de corriente.

DANGER If the installation requires a different power cord than the one supplied with the device, make sure you use a power cord displaying the mark of the safety agency that defines the regulations for power cords in your country. The mark is your assurance that the power cord can be used safely with the device.

GEFAHR Falls für die Installation ein anderes Stromkabel erforderlich ist (wenn das mit dem Gerät gelieferte Kabel nicht passt), müssen Sie sicherstellen, dass Sie ein Stromkabel mit dem Siegel einer Sicherheitsbehörde verwenden, die für die Zertifizierung von Stromkabeln in Ihrem Land zuständig ist. Das Siegel ist Ihre Garantie, dass das Stromkabel sicher mit Ihrem Gerät verwendet werden kann.

DANGER Si l'installation nécessite un cordon d'alimentation autre que celui fourni avec le dispositif, assurez-vous d'utiliser un cordon d'alimentation portant la marque de l'organisation responsable de la sécurité qui définit les normes et réglementations pour les cordons d'alimentation dans votre pays. Cette marque vous assure que vous pouvez utiliser le cordon d'alimentation avec le dispositif en toute sécurité.

DANGER If the installation requires a different power cord than the one supplied with the device, make sure you use a power cord displaying the mark of the safety agency that defines the regulations for power cords in your country. The mark is your assurance that the power cord can be used safely with the device.

PELIGRO Si la instalación requiere un cordón de corriente distinto al que se ha suministrado con el instrumento, verifique que usa un cordón de corriente que venga con la marca de la agencia de seguridad que defina las regulaciones para cordones de corriente en su país. Esta marca será su garantía de que el cordón de corriente puede ser utilizado con seguridad con el instrumento.

DANGER For safety reasons, the ESD wrist strap should contain a series 1 megaohm resistor.

GEFAHR Aus Sicherheitsgründen sollte ein EGB-Armband zum Schutz von elektronischen gefährdeten Bauelementen mit einem 1 Megaohm-Reihenwiderstand ausgestattet sein.

DANGER Pour des raisons de sécurité, la dragonne ESD doit contenir une résistance de série 1 méga ohm.

PELIGRO Por razones de seguridad, la correa de muñeca ESD deberá contener un resistor en serie de 1 mega ohmio.
